

# PV TECHNOLOGIES

## Silicon solar cells

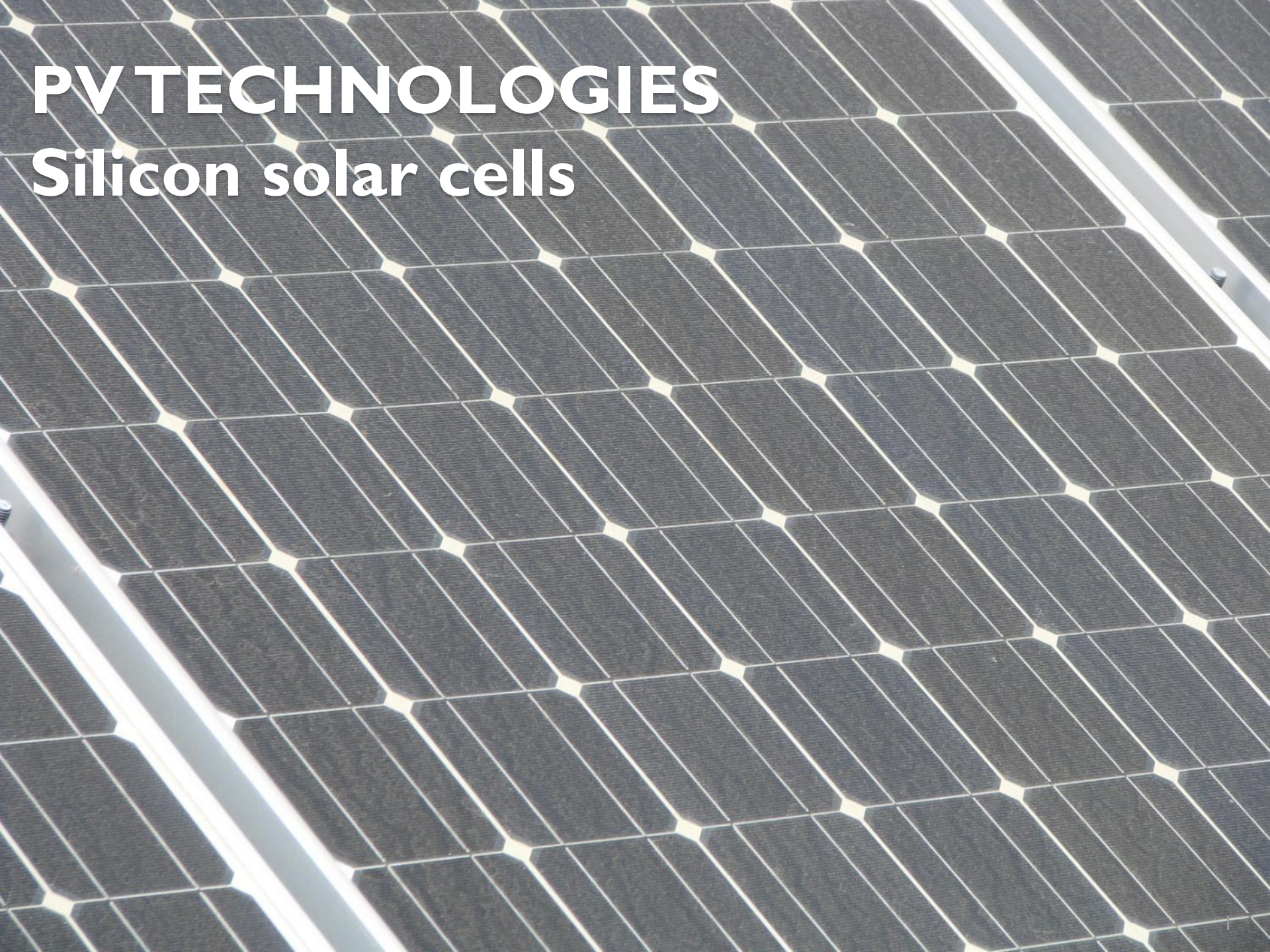

# PV TECHNOLOGIES

## Silicon solar cells

- Is there **a** c-Si technology?
- Feedstock
- Wafer
- Cells
- Module
- Other silicon concepts
- Materials availability

# PV TECHNOLOGIES

## Silicon solar cells

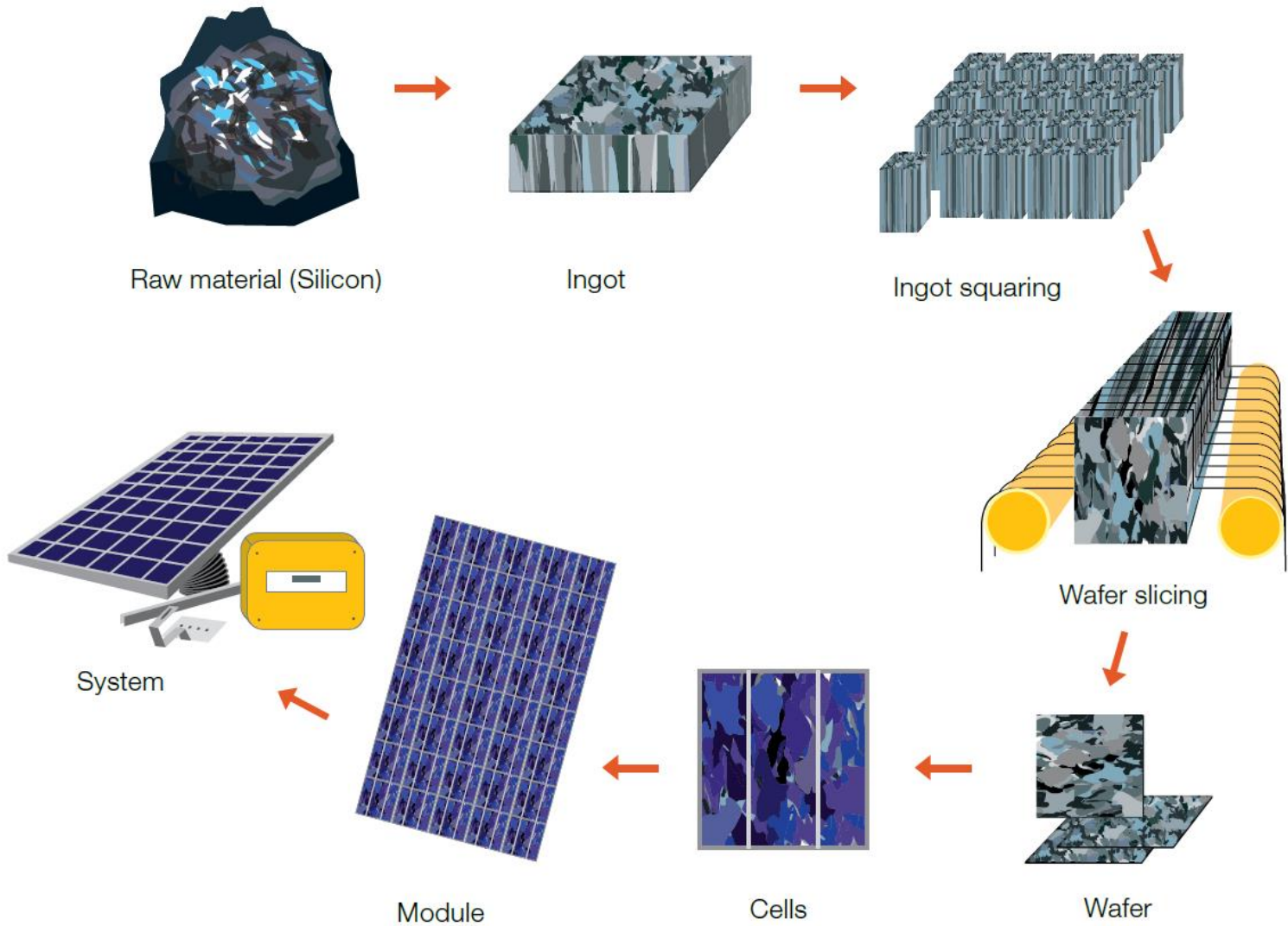

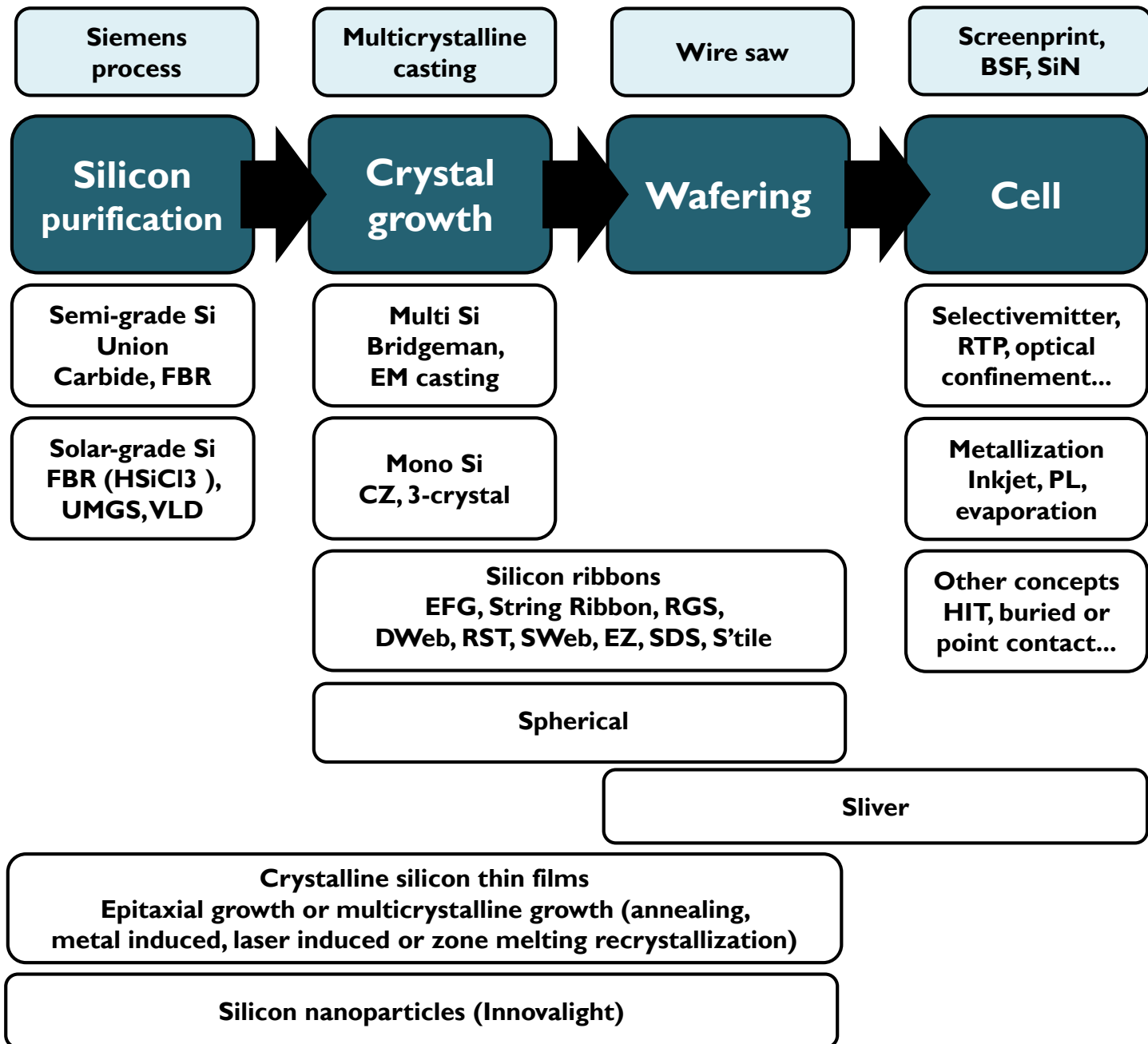

# PV TECHNOLOGIES

## Silicon solar cells

**Silicon** is the second most abundant element on Earth after oxygen (28% of the Earth's crust). Its most familiar forms are sand and quartzite (the latter one is more pure).

Each silicon atom is bonded to four neighbouring atoms.

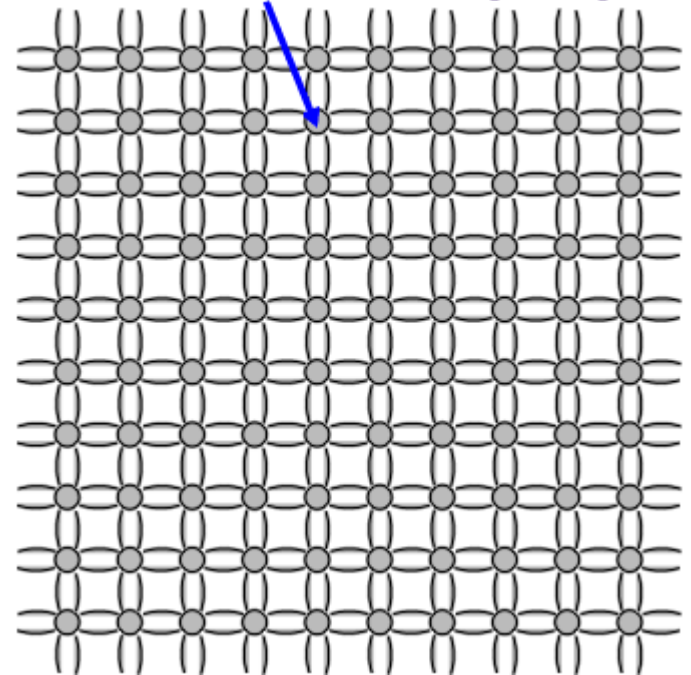

# PV TECHNOLOGIES

## Silicon solar cells

**Feedstock:** obtaining hyperpure silicon from gas phase

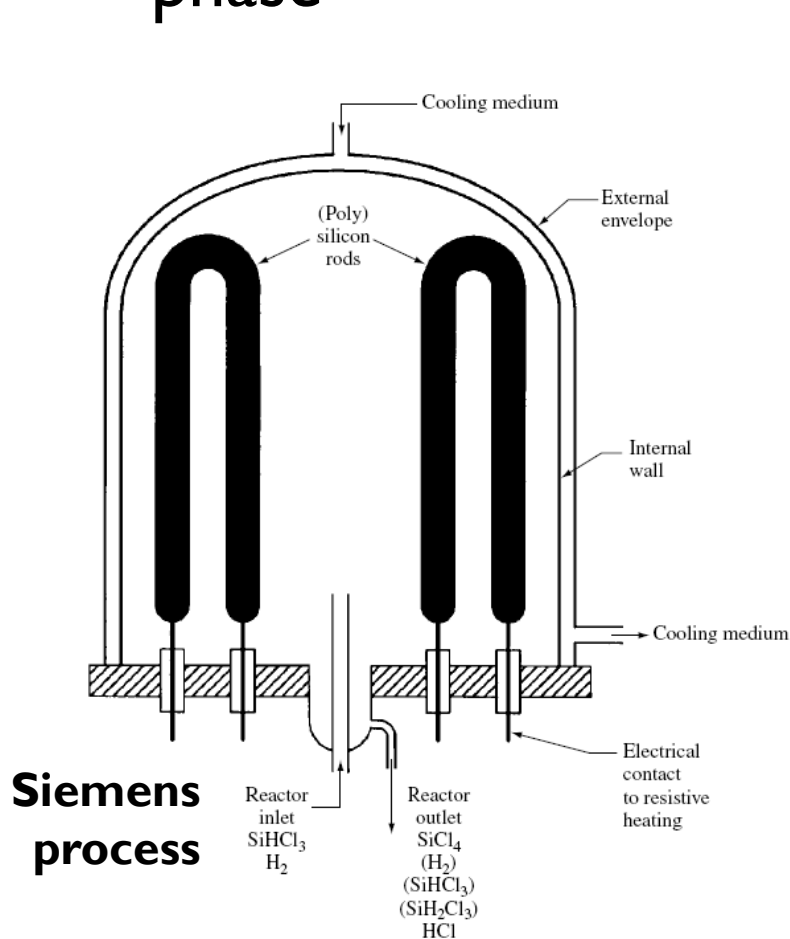

### Fluidized bed reactor

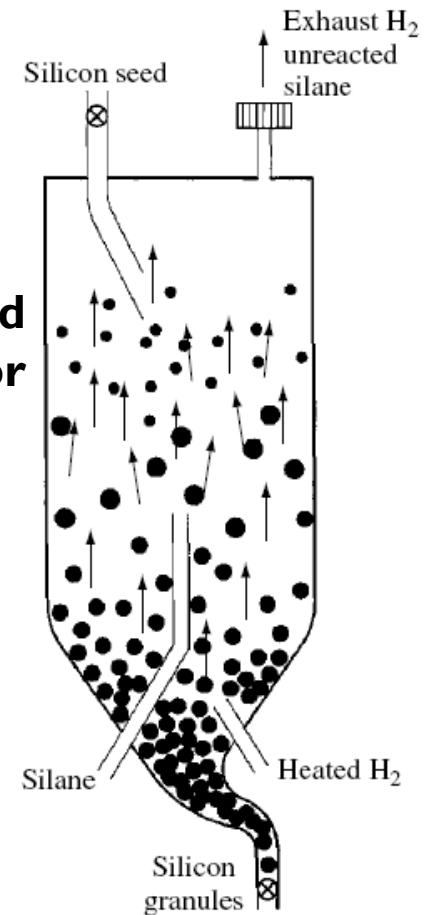

# PV TECHNOLOGIES

## Silicon solar cells

**Feedstock:** obtaining hyperpure silicon from gas phase



# PV TECHNOLOGIES

## Silicon solar cells

**Crystalline silicon** may be used in PV in different forms:

Descriptor	Symbol	Grain Size	Common Growth Techniques
Single crystal	sc-Si	>10cm	Czochralski (CZ) float zone (FZ)
Multicrystalline	mc-Si	1mm-10cm	Cast, sheet, ribbon
Polycrystalline	pc-Si	1 $\mu$ m-1mm	Chemical-vapour deposition
Microcrystalline	$\mu$ c-Si	<1 $\mu$ m	Plasma deposition

# PV TECHNOLOGIES

## Silicon solar cells

**Czochralski silicon** is the standard for electronics industry. High quality (mono) with contamination with oxygen and carbon into the melt.

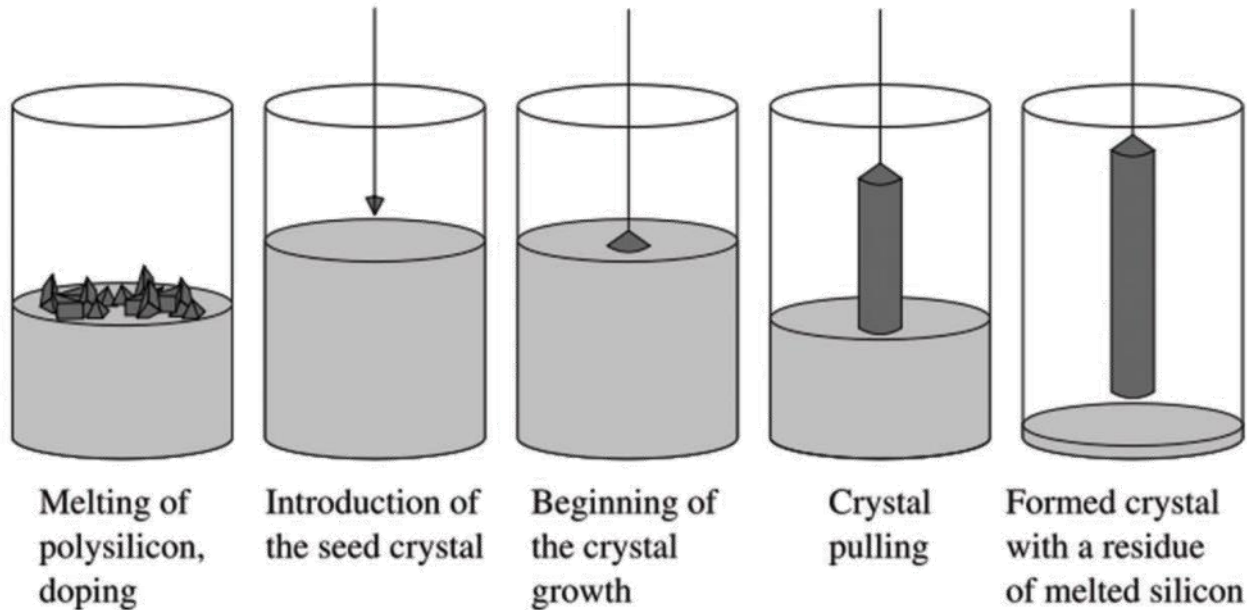

# PV TECHNOLOGIES

## Silicon solar cells

Czochralski silicon  
Growth rate: 5cm/hour

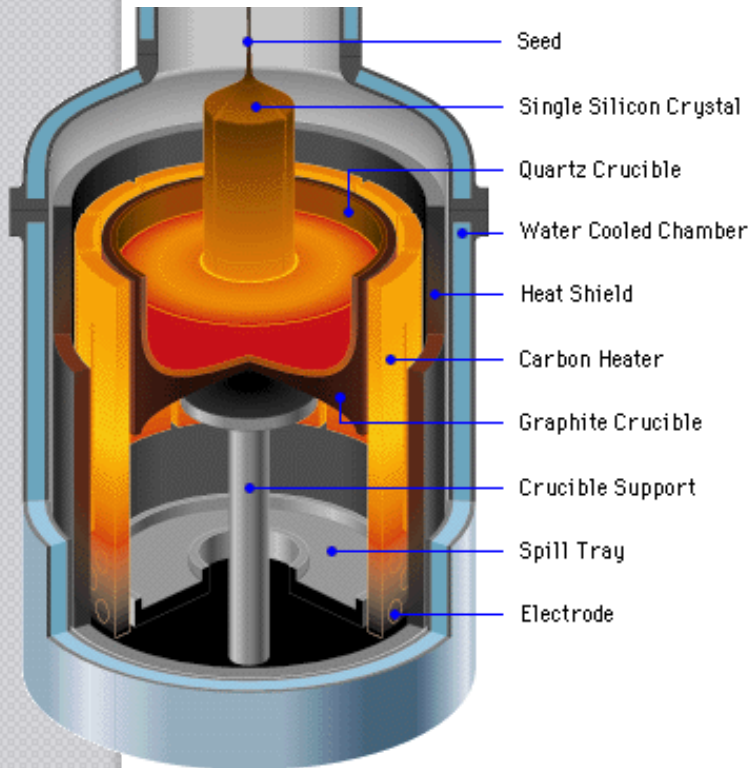

# PV TECHNOLOGIES

## Silicon solar cells

**Float zone** silicon is the best quality silicon

No contamination but very expensive. Only for very demanding applications.

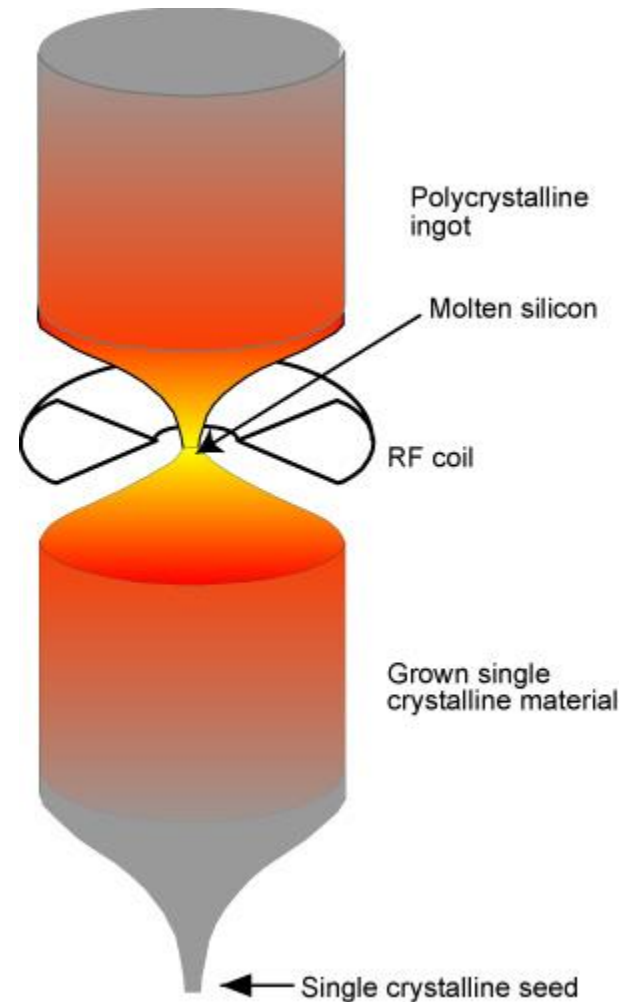

# PV TECHNOLOGIES

## Silicon solar cells

**Multicrystalline silicon** offers acceptable quality but at lower cost

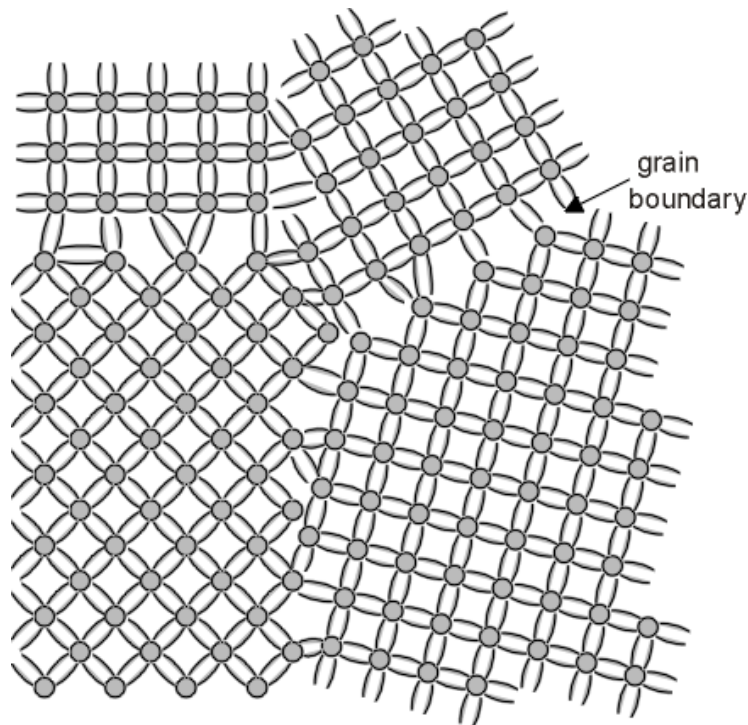

# PV TECHNOLOGIES

## Silicon solar cells

**Multicrystalline silicon** offers acceptable quality but at lower cost.

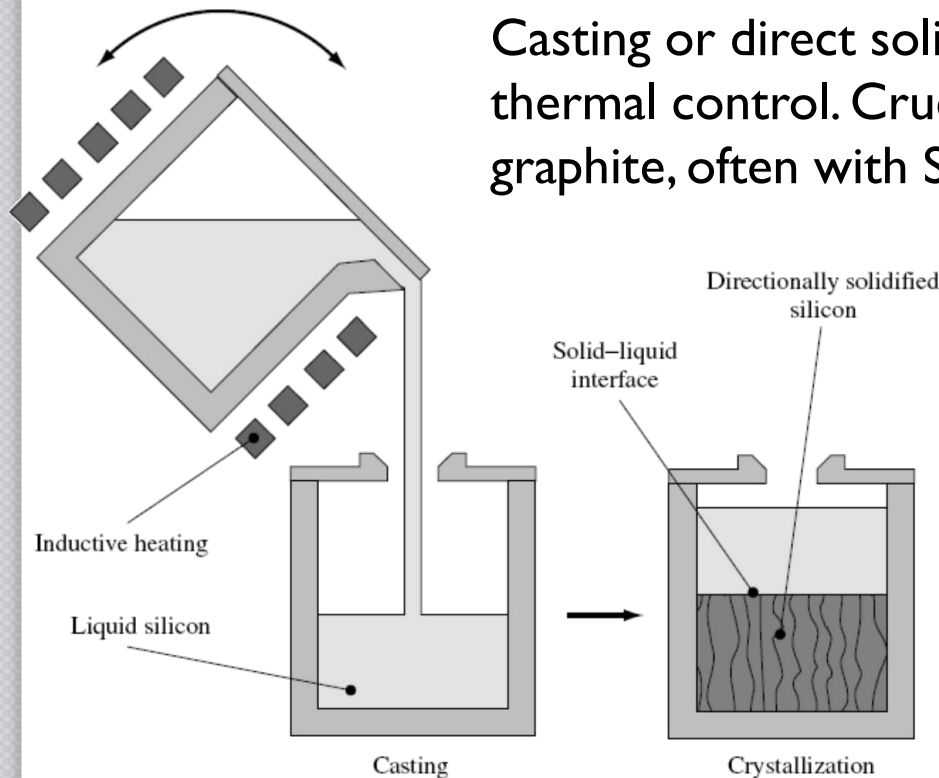

Casting or direct solidification, requires careful thermal control. Crucible usually made of quartz or graphite, often with  $\text{Si}_3\text{N}_4$  coating.



Typical casting:  
240kg/56 hours

# PV TECHNOLOGIES

## Silicon solar cells

**Multicrystalline ingots** require sawing.

Kerf loss and saw damage removal is significant (and costly).

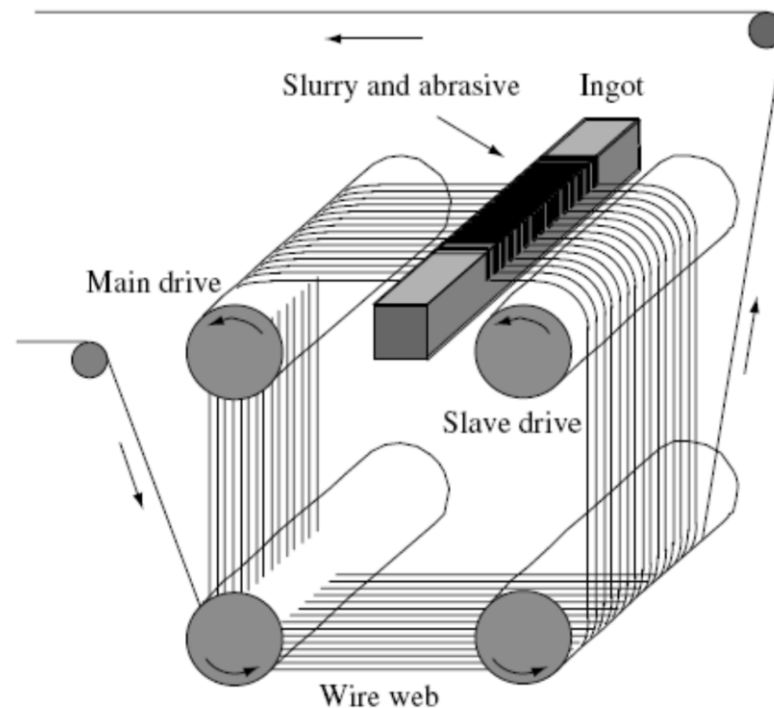

# PV TECHNOLOGIES

## Silicon solar cells

Multicrystalline wafers may be grown directly in **sheet or ribbon** form.

- Edge defined film fed growth (EFG)
- String ribbon (SR)
- Ribbon growth on substrate (RGS)
- Dendritic web
- Sheet silicon
- ...

# PV TECHNOLOGIES

## Silicon solar cells

Multicrystalline wafers may be grown directly in **sheet or ribbon** form.

- Edge defined film fed growth (**EFG**)

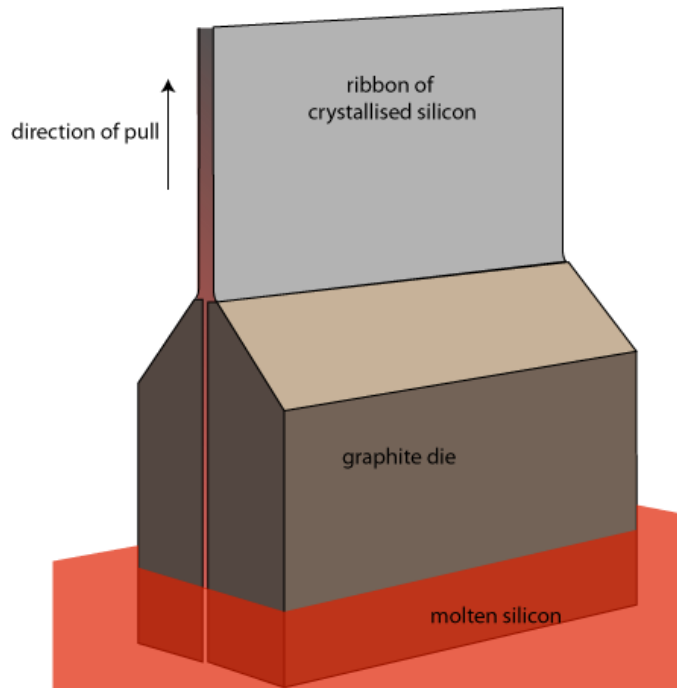

# PV TECHNOLOGIES

## Silicon solar cells

Multicrystalline wafers may be grown directly in **sheet or ribbon** form.

- **String** ribbon (SR)

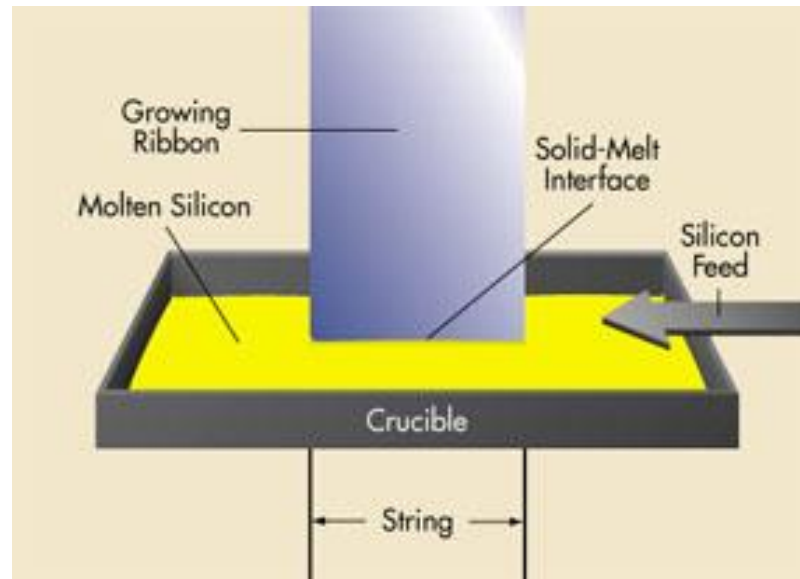

# PV TECHNOLOGIES

## Silicon solar cells

Multicrystalline wafers may be grown directly in **sheet or ribbon** form.

- Ribbon growth on substrate (**RGS**)

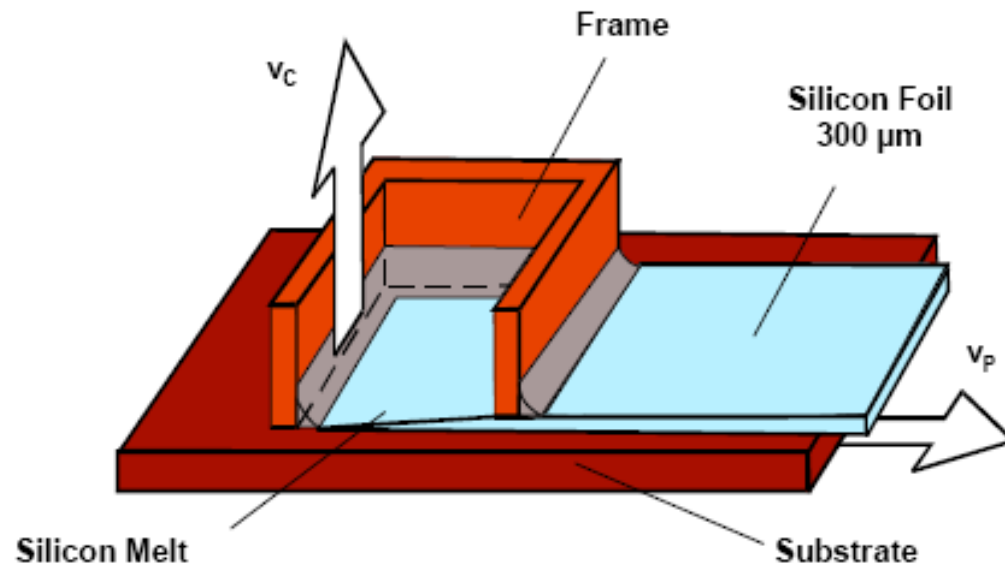

# PV TECHNOLOGIES

## Silicon solar cells

### Quasi-monocrystalline production process using a seed

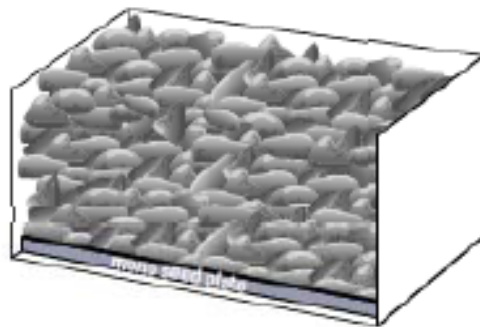

Polysilicon is loaded above the seed plate

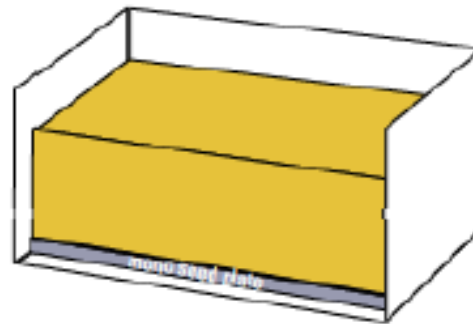

Seed at the bottom is kept solid during the melting process

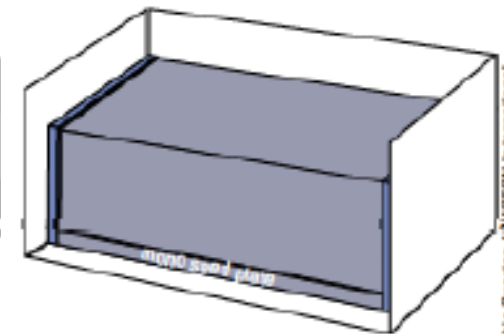

Casted quasi-monocrystalline silicon ingot

graphic: Sophia Quarten / PHOTO INTERNATIONAL

#### Main issues to address:

- What to do with edges (~30% volume)
- Higher cost than mcSi due to seeding and slower crystallization

# PV TECHNOLOGIES

## Silicon solar cells

### Bright future for quasi mono?

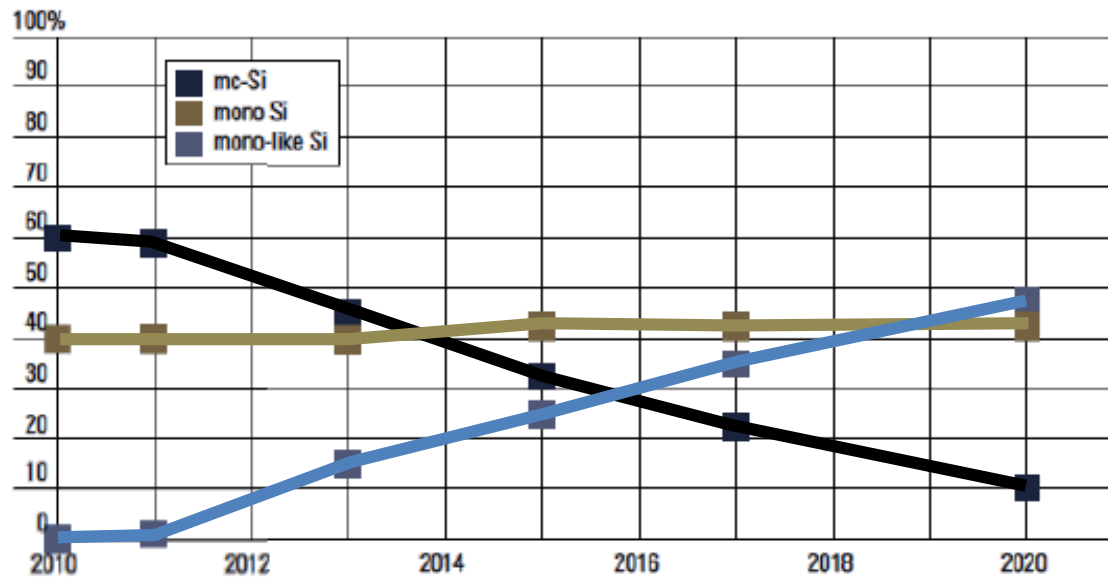

Source: SEMI PV Group

**High expectations** but markets seems to have given up on quasi-mono...

# PV TECHNOLOGIES

## Silicon solar cells



# PV TECHNOLOGIES

## Silicon solar cells

**Check:**  
PVCDROM  
Chapter 6

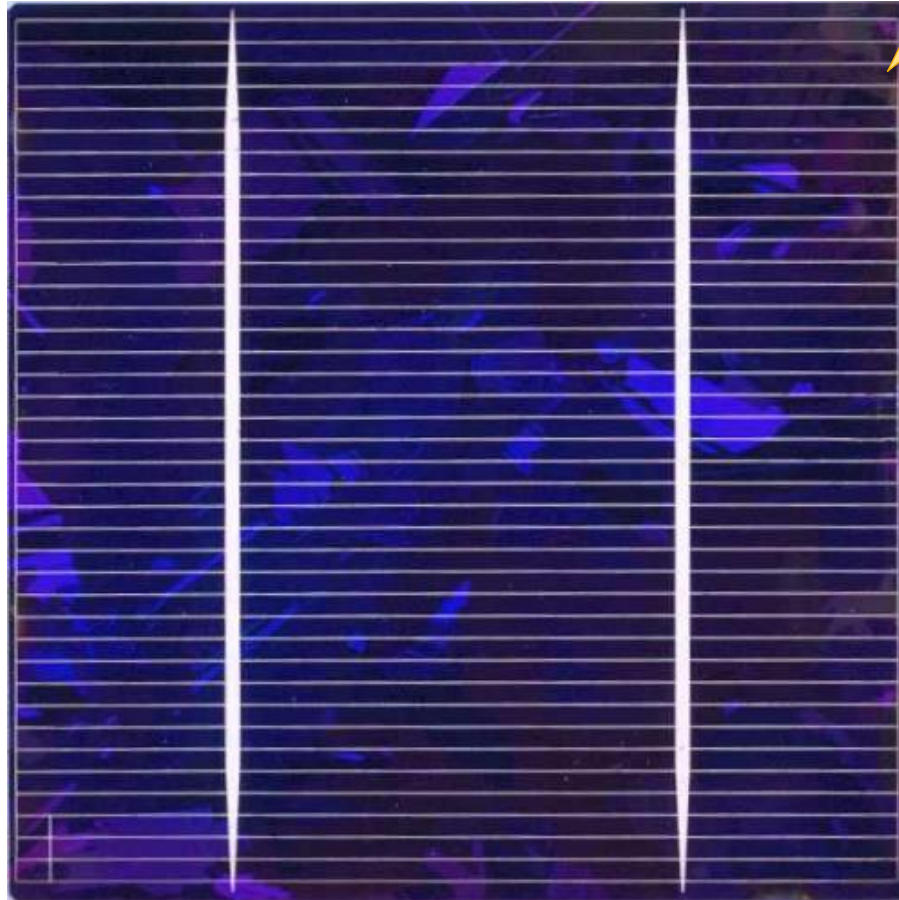

# PV TECHNOLOGIES

## Silicon solar cells

Typical screen printed silicon solar cell manufacturing process

- Saw damage etch
- Phosphorous diffusion
- Edge isolation
- Back contact print
- Firing
- Anti reflective coating
- Front contact print
- Firing
- Testing & sorting

# PV TECHNOLOGIES

## Silicon solar cells

Typical screen printed silicon solar cell manufacturing process

- Saw damage etch
- Phosphorous diffusion
- Edge isolation
- Back contact print
- Firing
- Anti reflective coating
- Front contact print
- Firing
- Testing & sorting

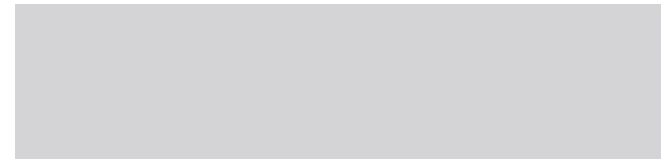

# PV TECHNOLOGIES

## Silicon solar cells

Typical screen printed silicon solar cell manufacturing process

- Saw damage etch
- **Phosphorous diffusion**
- Edge isolation
- Back contact print
- Firing
- Anti reflective coating
- Front contact print
- Firing
- Testing & sorting

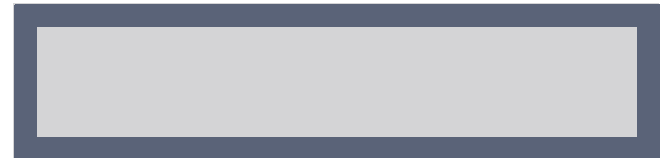

# PV TECHNOLOGIES

## Silicon solar cells

Typical screen printed silicon solar cell manufacturing process

- Saw damage etch
- Phosphorous diffusion
- **Edge isolation**
- Back contact print
- Firing
- Anti reflective coating
- Front contact print
- Firing
- Testing & sorting



# PV TECHNOLOGIES

## Silicon solar cells

### Typical screen printed silicon solar cell manufacturing process

- Saw damage etch
- Phosphorous diffusion
- Edge isolation
- **Back contact print**
- Firing
- Anti reflective coating
- Front contact print
- Firing
- Testing & sorting

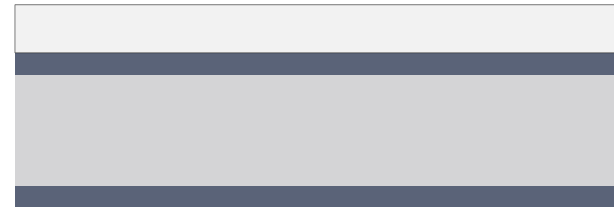

# PV TECHNOLOGIES

## Silicon solar cells

### Typical screen printed silicon solar cell manufacturing process

- Saw damage etch
- Phosphorous diffusion
- Edge isolation
- Back contact print
- **Firing**
- Anti reflective coating
- Front contact print
- Firing
- Testing & sorting

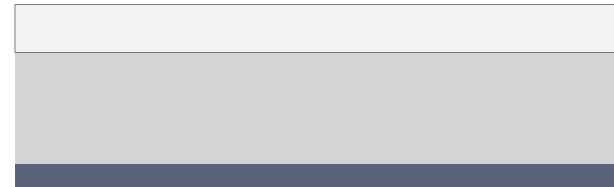

# PV TECHNOLOGIES

## Silicon solar cells

### Typical screen printed silicon solar cell manufacturing process

- Saw damage etch
- Phosphorous diffusion
- Edge isolation
- Back contact print
- Firing
- **Anti reflective coating**
- Front contact print
- Firing
- Testing & sorting

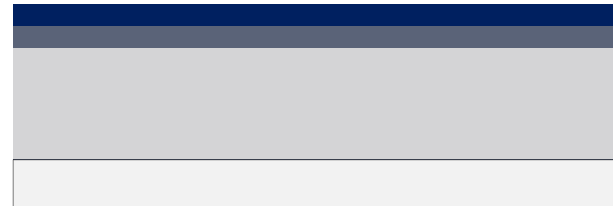

# PV TECHNOLOGIES

## Silicon solar cells

### Typical screen printed silicon solar cell manufacturing process

- Saw damage etch
- Phosphorous diffusion
- Edge isolation
- Back contact print
- Firing
- Anti reflective coating
- **Front contact print**
- Firing
- Testing & sorting



# PV TECHNOLOGIES

## Silicon solar cells

### Typical screen printed silicon solar cell manufacturing process

- Saw damage etch
- Phosphorous diffusion
- Edge isolation
- Back contact print
- Firing
- Anti reflective coating
- Front contact print
- **Firing**
- Testing & sorting

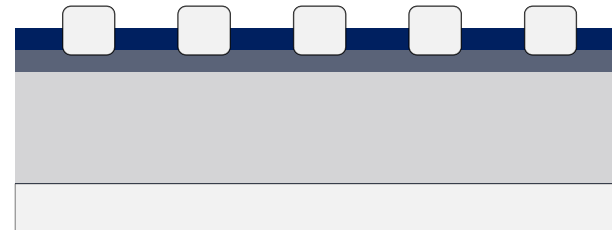

# PV TECHNOLOGIES

## Silicon solar cells

**Phosphorous diffusion** can be inline continuous or batch type

P source:  $\text{POCl}_3$



# PV TECHNOLOGIES

## Silicon solar cells

**Screenprinting** using silver paste is standard.

Inkjet alternatives and/or other materials are fashionable research topics.

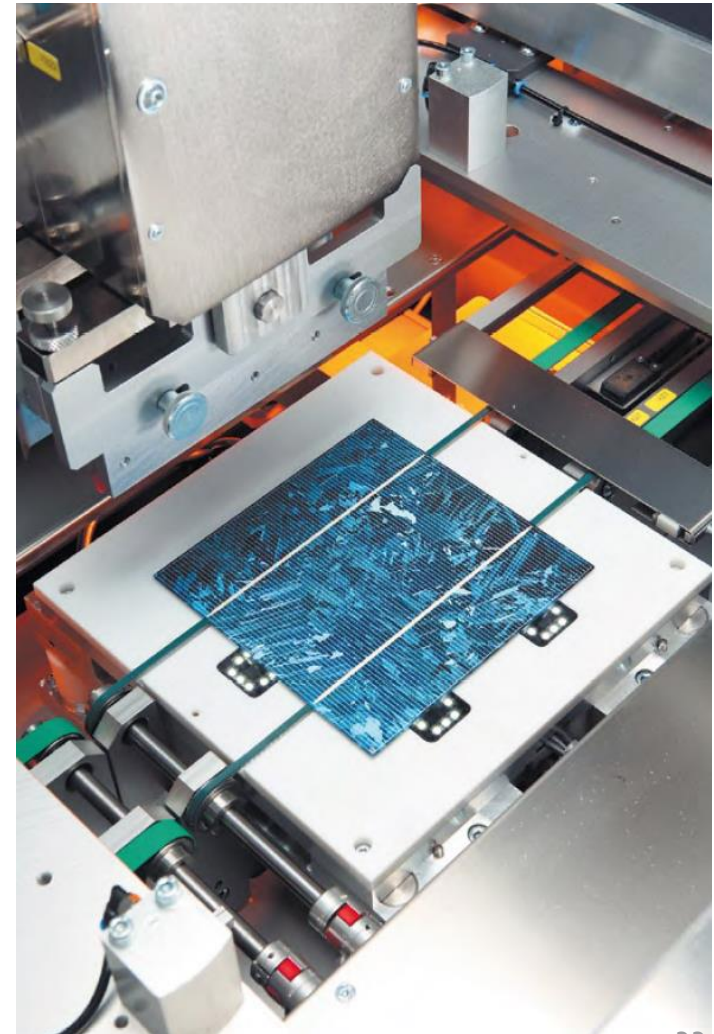

# PV TECHNOLOGIES

## Silicon solar cells

**Handling** thin wafers and keeping high yields may be challenging



# PV TECHNOLOGIES

## Silicon solar cells

### **PV silicon module**

- **Packing** density
- Interconnection PV cells
- Encapsulation

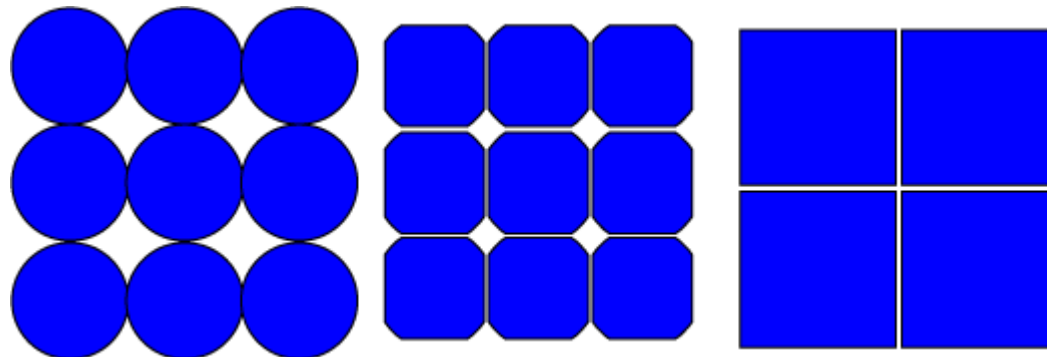

# PV TECHNOLOGIES

## Silicon solar cells

### PV silicon module

- Packing density
- **Interconnection** PV cells
- Encapsulation

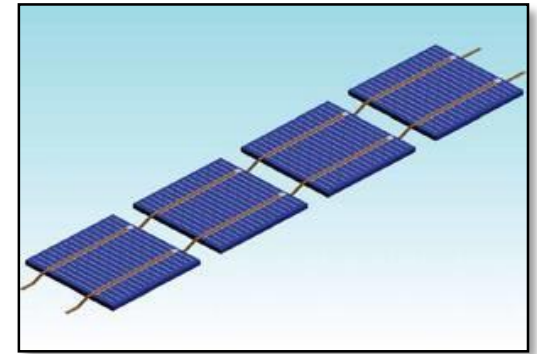

A typical module has  
36 cells in series

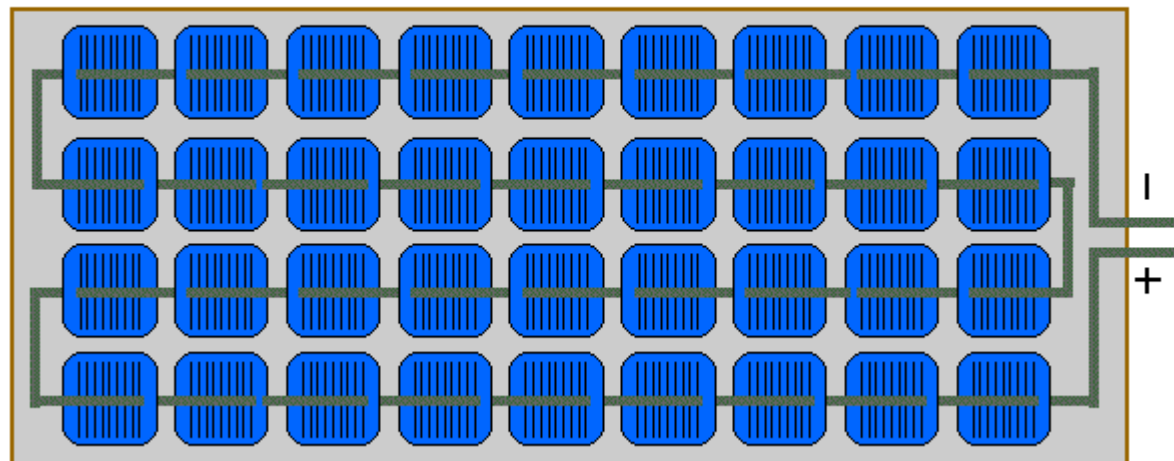

# PV TECHNOLOGIES

## Silicon solar cells

### PV silicon module

- Packing density
- Interconnection PV cells
- **Encapsulation**
  - Good transmittance but UV absorbance
  - Rigidity to withstand mechanical loads
  - Protection from weather agents and humidity

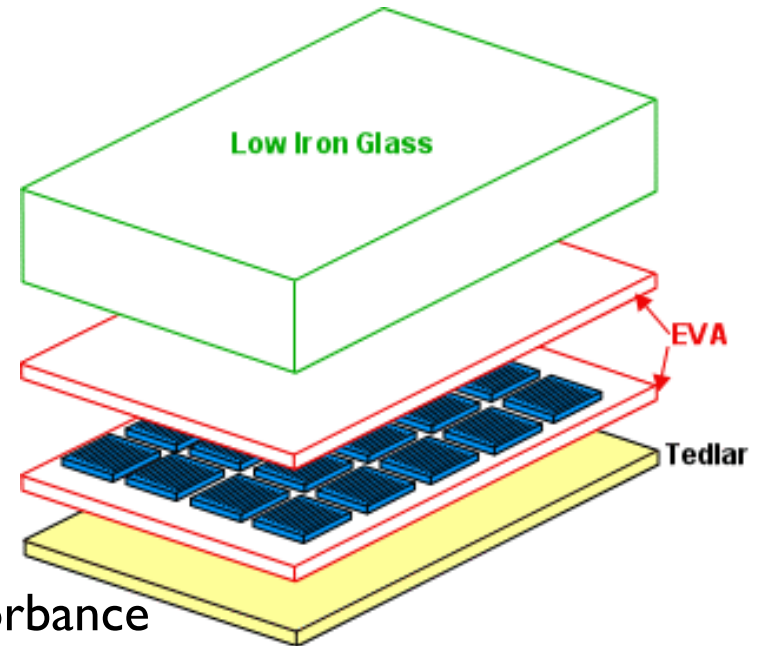

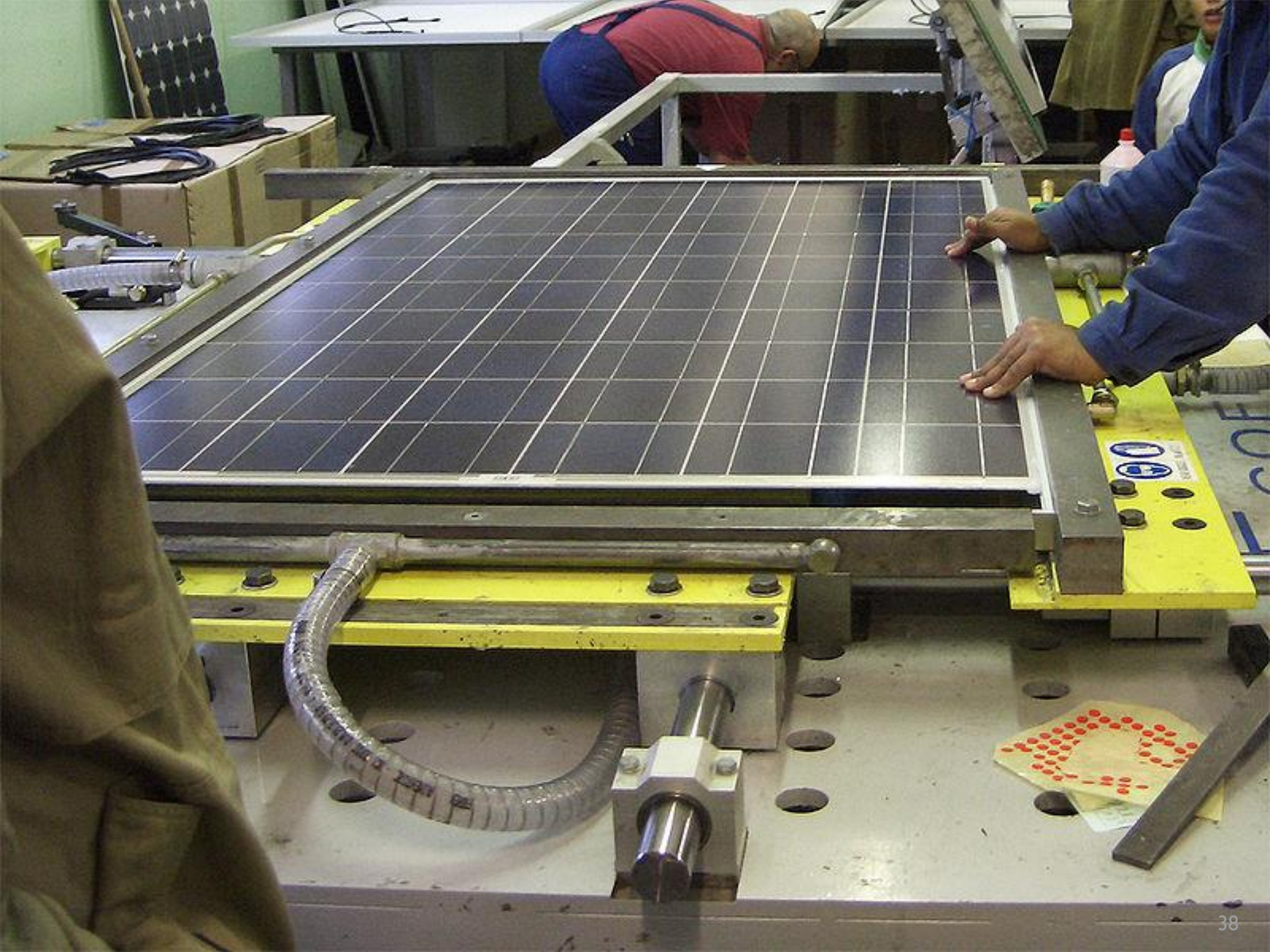

# PV TECHNOLOGIES

## Silicon solar cells

Is there **a** c-Si technology?

# PV TECHNOLOGIES

## Silicon solar cells

Is there **a** c-Si technology?

PERL solar cell

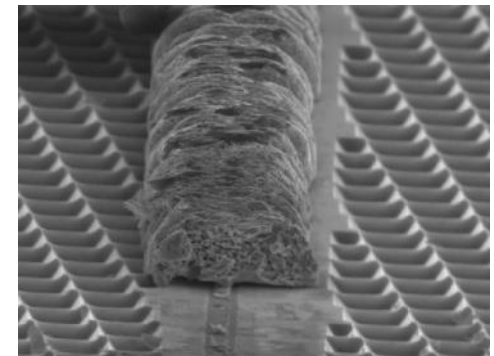
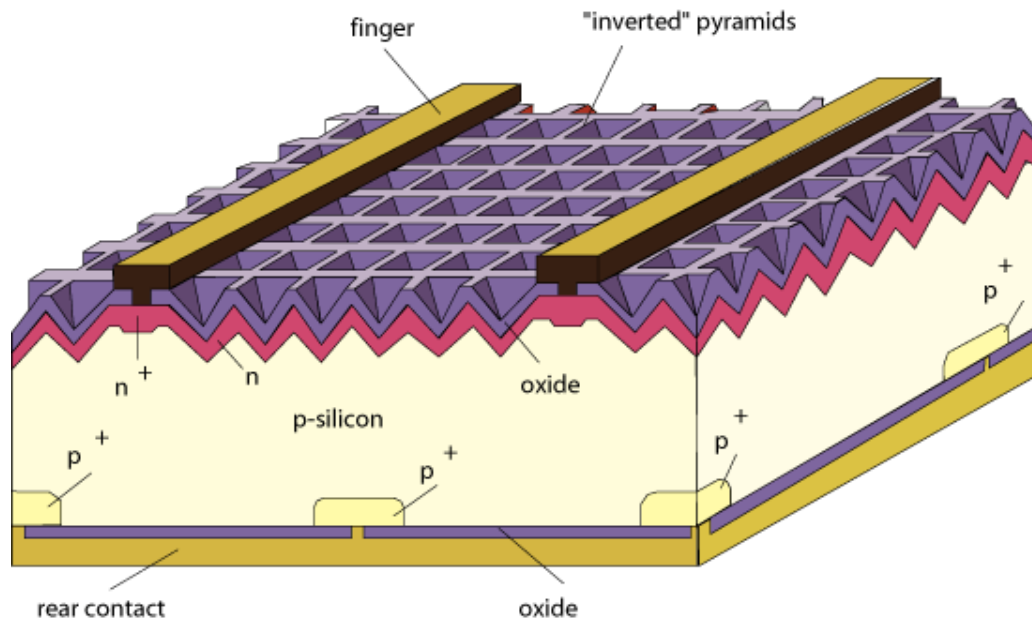

# PV TECHNOLOGIES

## Silicon solar cells

Is there **a** c-Si technology?

Buried contact solar cell

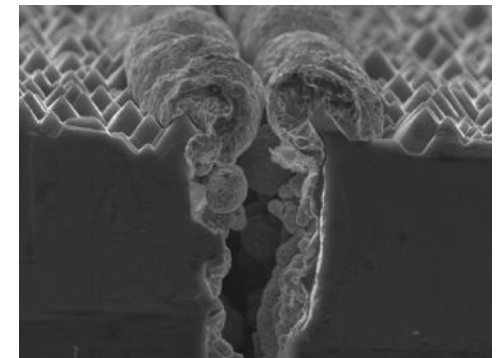
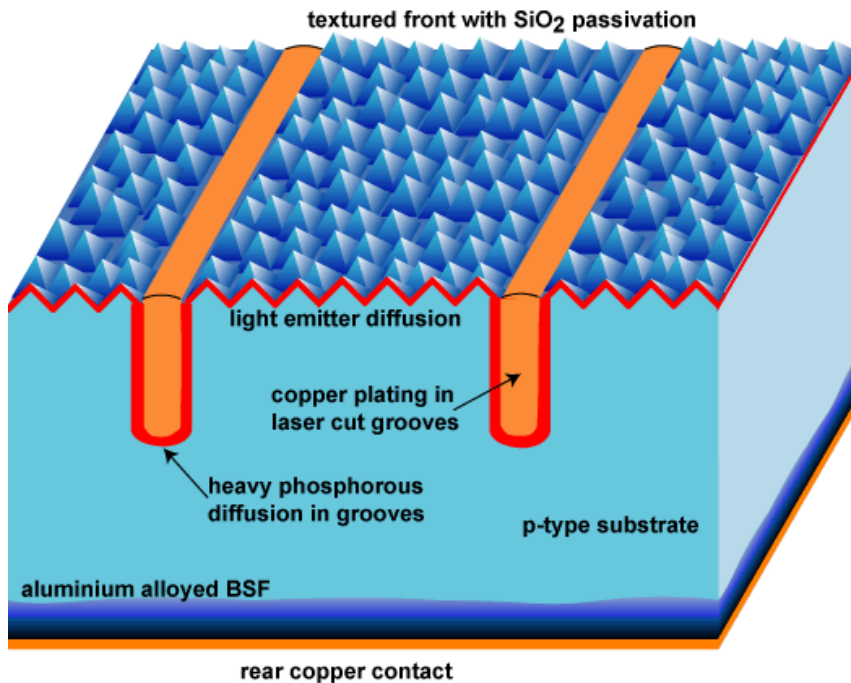

# PV TECHNOLOGIES

## Silicon solar cells

Is there **a** c-Si technology?

Rear interdigitated (RISE) solar cell

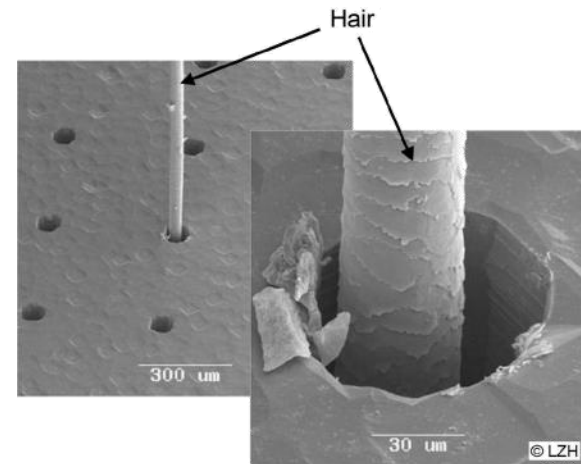
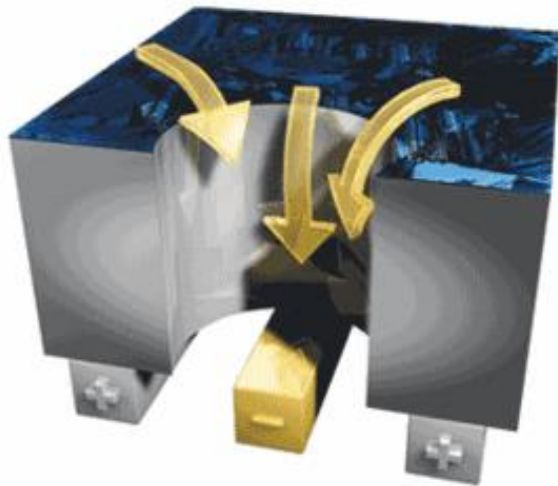

# PV TECHNOLOGIES

## Silicon solar cells

Is there **a** c-Si technology?

Rear interdigitated (RISE) solar cell

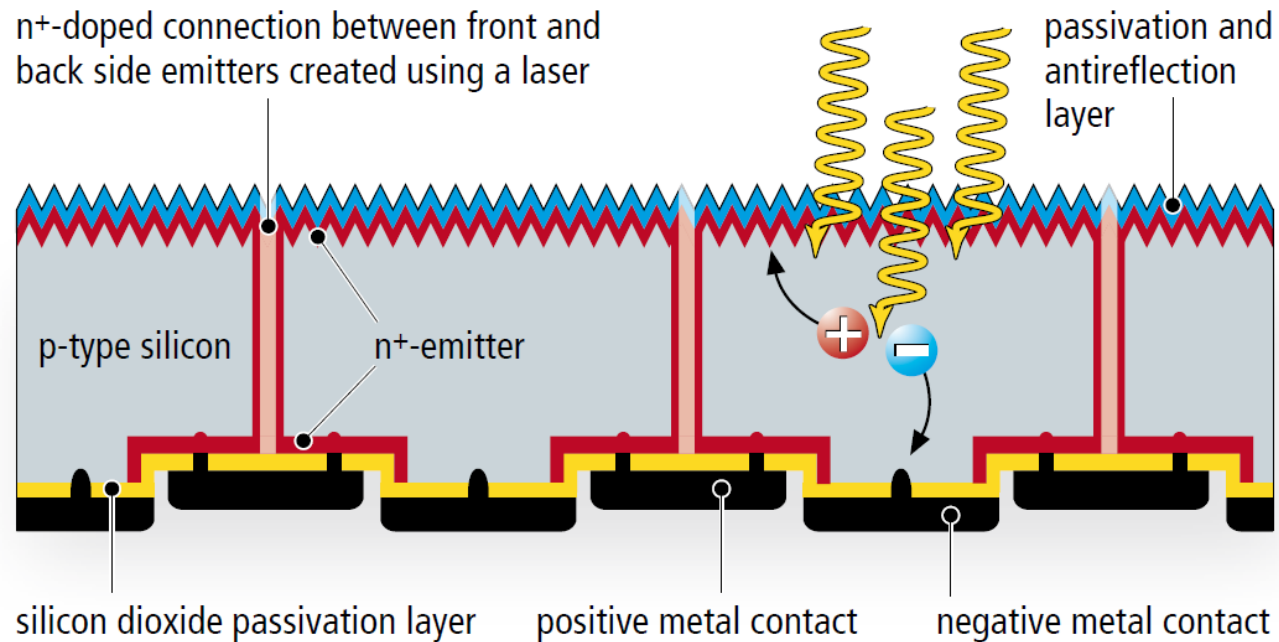

# PV TECHNOLOGIES

## Silicon solar cells

Is there **a** c-Si technology?

Spherical solar cell

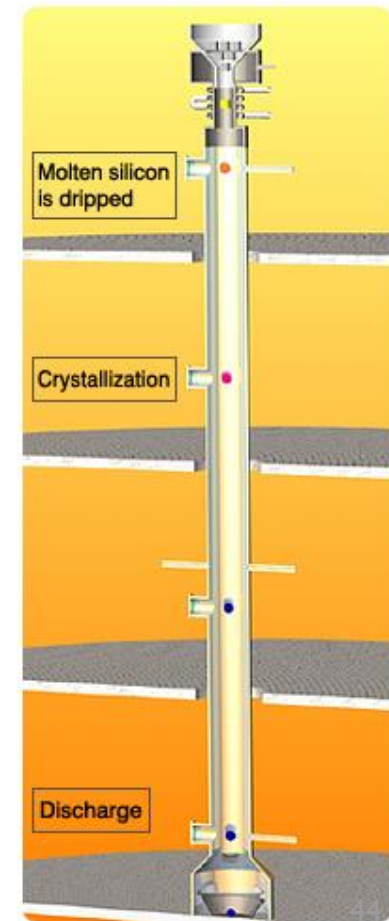
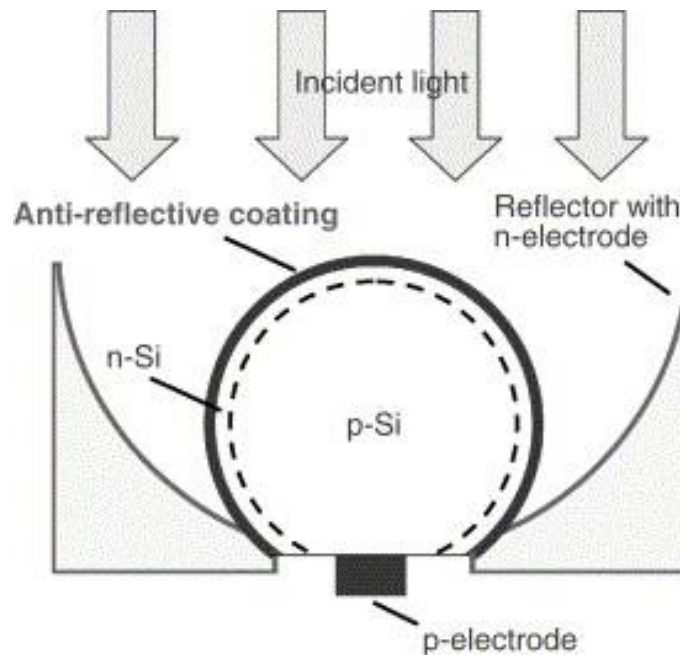

# PV TECHNOLOGIES

## Silicon solar cells

Is there **a** c-Si technology?

Sliver solar cell

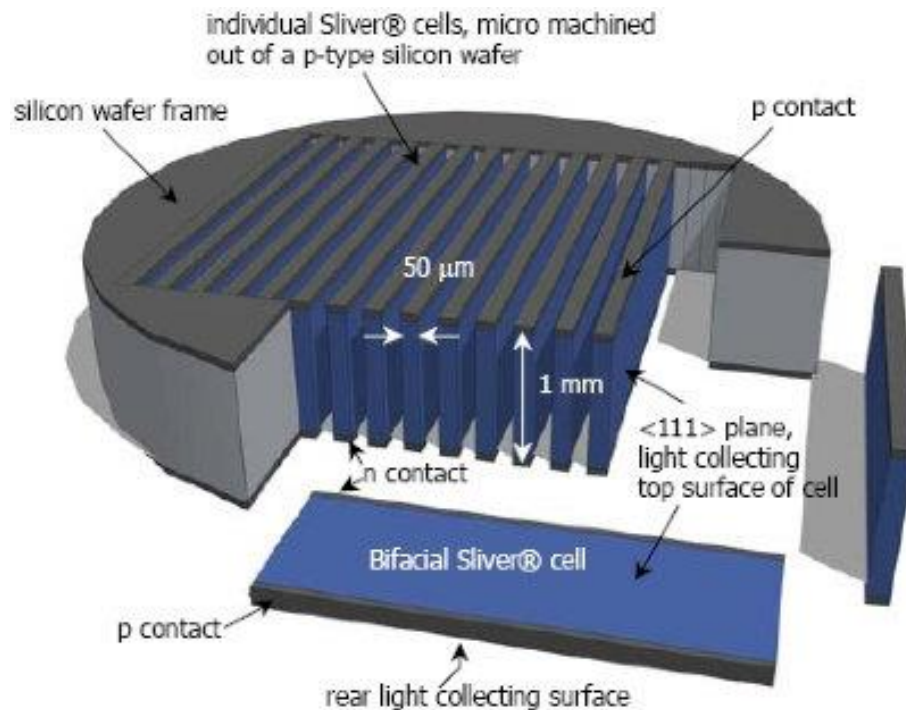

# PV TECHNOLOGIES

## Silicon solar cells

### Materials availability

- Silicon is **very** abundant...
- Silver paste for the contacts will be a material bottleneck
- Other (temporary) bottlenecks:
  - Module glass
  - Tedlar
  - EVA

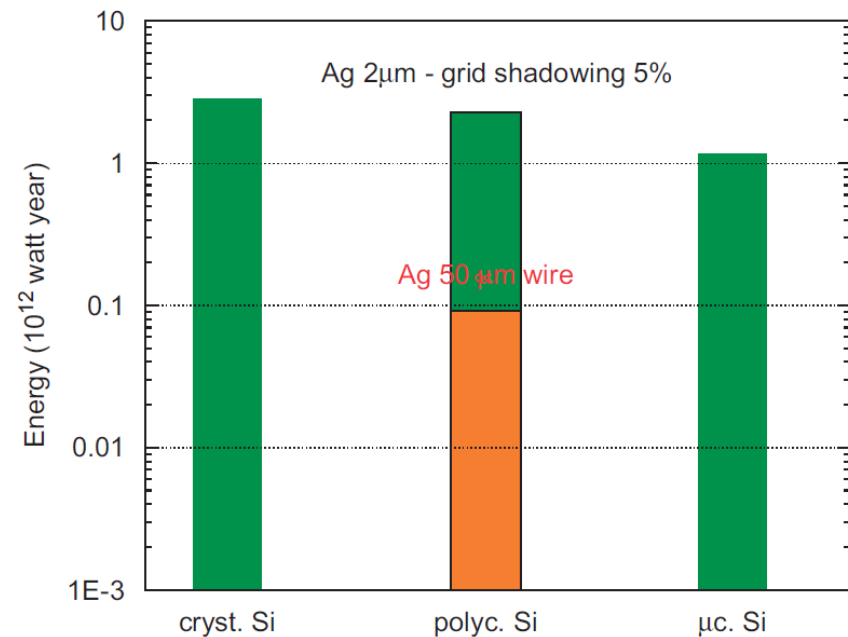
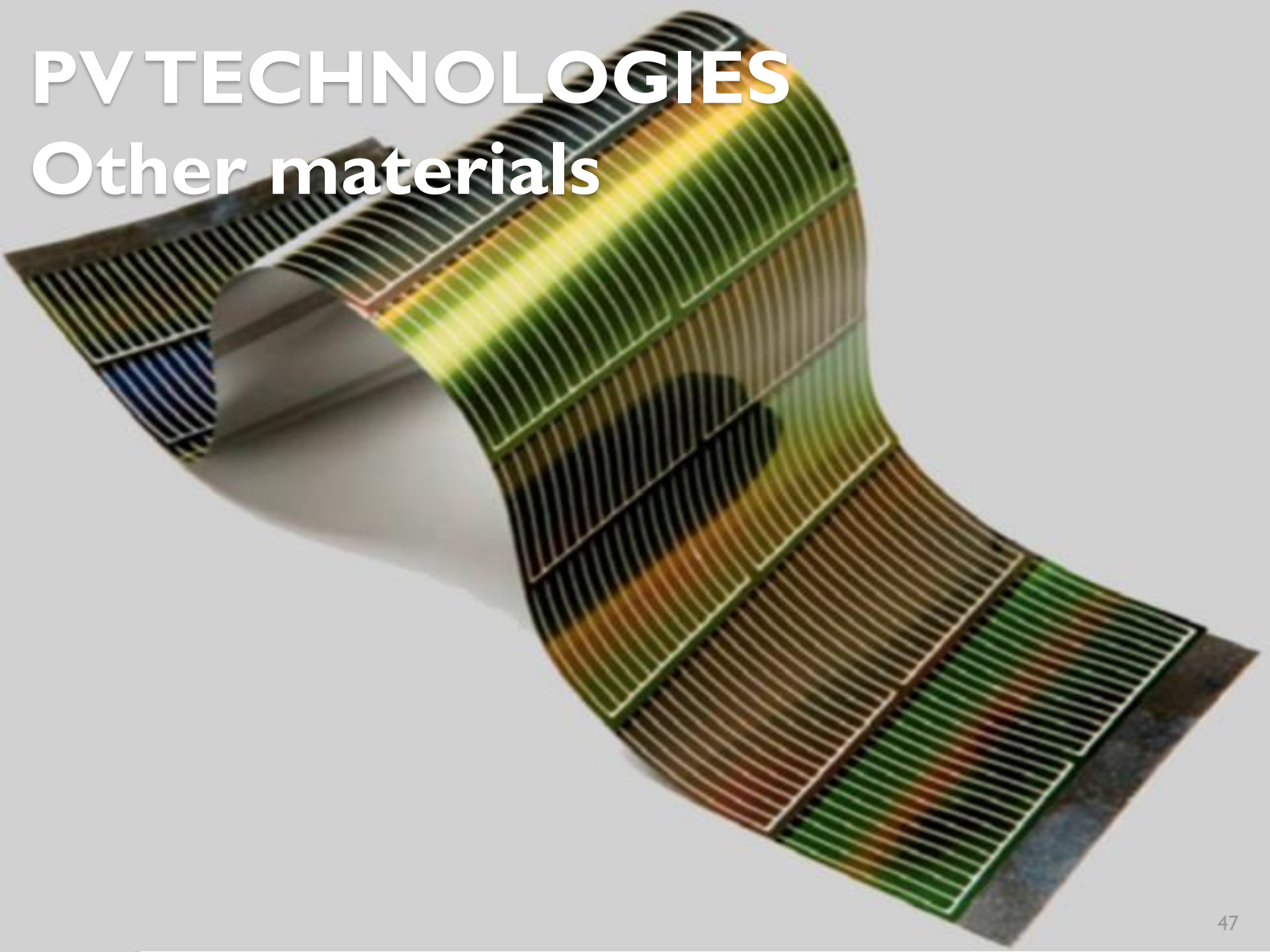

Fig. 3. Potential energy limits imposed by global silver (Ag) reserves for bulk-like silicon photovoltaic technologies. Calculations assume AM1.5 efficiencies of 24.7% (Ref. [8]) and 20.3% (Ref. [7]) for crystalline and large grain poly-crystalline solar cells. The orange shaded area represents limits reached using 50 μm-thick Ag ribbons. The green shaded area represents limits estimated using a 2 μm thick Ag electrodes and 5% grid shadowing.

# PV TECHNOLOGIES

## Other materials



# PV TECHNOLOGIES

## Other technologies

- Other concepts, materials & technologies
  - a-Si
  - CIGS
  - CdTe
- It's not only about efficiency (nor cost!)

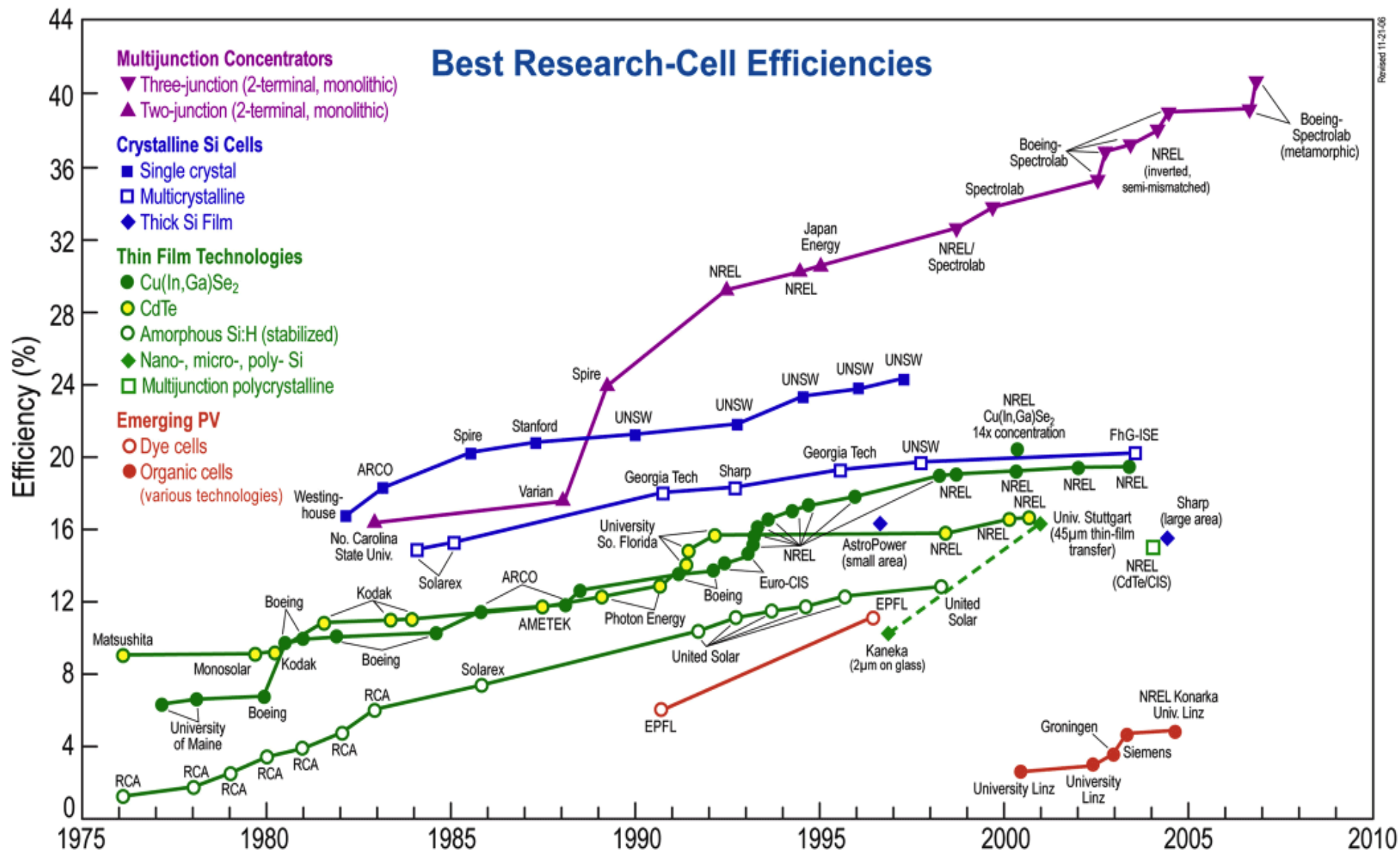

Revised 11/21/08

# PV TECHNOLOGIES

## Amorphous silicon solar cells

- **Amorphous** – commonly applied to noncrystalline materials prepared by deposition from gases
- **First** working a-Si based solar cell: Carlson D, Wronski C, *Appl. Phys. Lett.* 28, 671 (1976)
- **Cheaper** deposition
- Hydrogenated amorphous silicon (a-Si:H) has higher absorption coefficient than crystalline silicon – much **thinner** ( $< 1 \mu\text{m}$ ) solar cells are possible

# PV TECHNOLOGIES

## Amorphous silicon solar cells

### **p-i-n** configuration

- Electron-hole pairs are generated in the intrinsic 'thick' layer and
- Separated by the built electric field

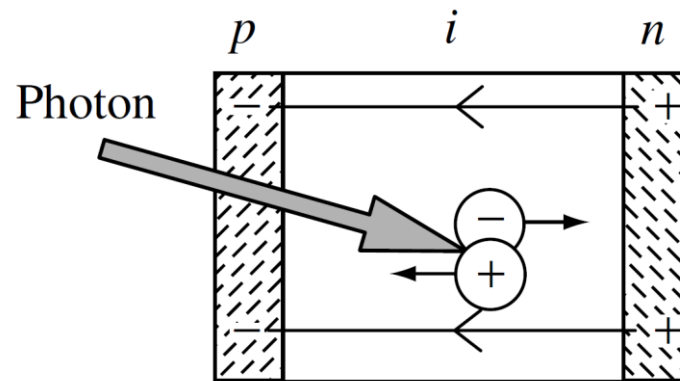

*pin* photodiode

# PV TECHNOLOGIES

## Amorphous silicon solar cells

Very thin active layer ( $< 1 \mu\text{m}$ ) thus:  
requires **substrate**

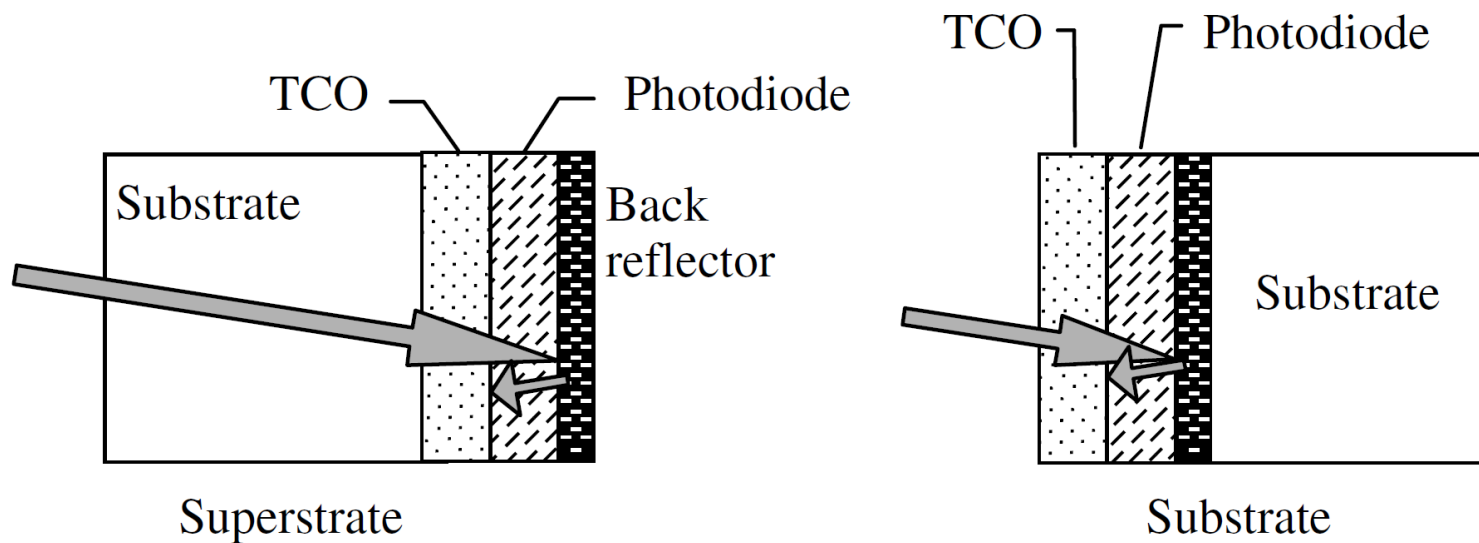

Substrate may be glass:  
useful for building **integrated** PV

Substrate may be foil:  
useful for **flexible** solar cells

# PV TECHNOLOGIES

## Amorphous silicon solar cells

To increase efficiency, more junctions (**tandem** configuration) may be added

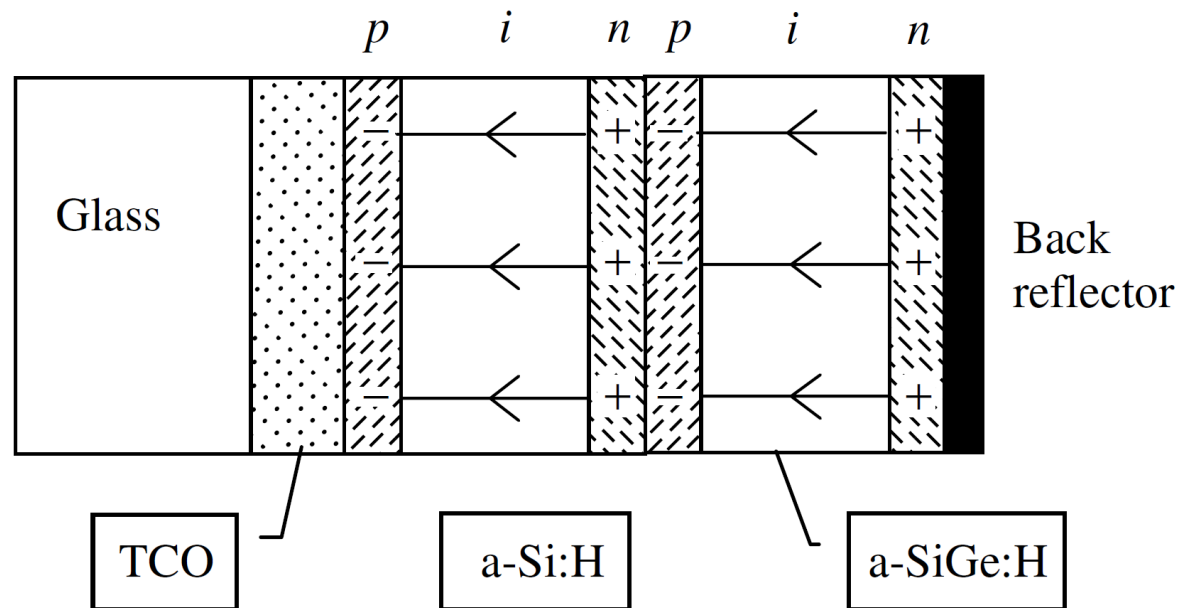

# PV TECHNOLOGIES

## Amorphous silicon solar cells

Significant decline in their efficiency during their first few hundred hours of illumination: **Staebler–Wronski effect**

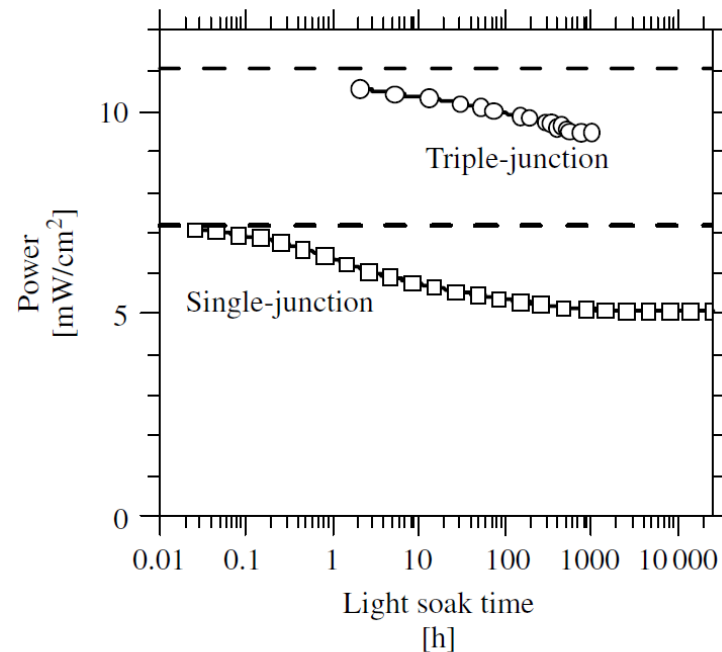

Staebler D, Wronski C,  
*Appl. Phys. Lett.*  
31, 292 (1977).

**Figure 12.5** The conversion efficiency in a-Si:H-based solar cells declines noticeably upon the first exposure to sunlight. The figure illustrates this decline under a solar simulator (100 mW/cm<sup>2</sup>) for a single-junction cell (260-nm *i*-layer thickness) and for a triple-junction module made at United Solar Systems Corp. [14, 15]; the dashed lines indicate the initial power measured for each device

# PV TECHNOLOGIES

## Amorphous silicon solar cells

**PECVD** - Plasma enhanced chemical vapour deposition (a.k.a. RF glow discharge deposition)

- $\text{SiH}_4 + \text{H}_2$  into the chamber
- RF is applied and generates plasma
- plasma excites and decomposes the gas and generates radicals and ions
- that will diffuse onto the heated substrate

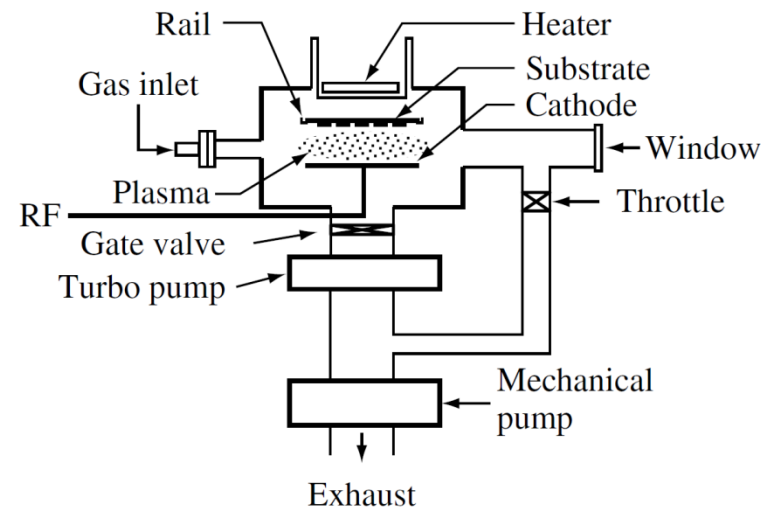

# PV TECHNOLOGIES

## Amorphous silicon solar cells

### Oerlikon

based on process developed at the University of Neuchâtel

### Applied Materials

based on process developed at Research Center Jülich (FZJ)

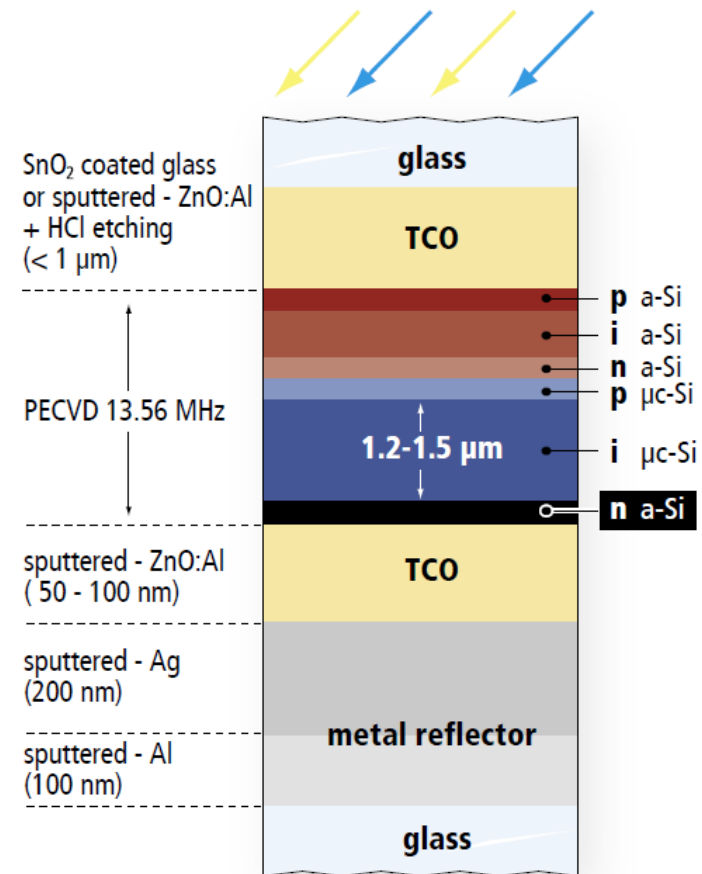
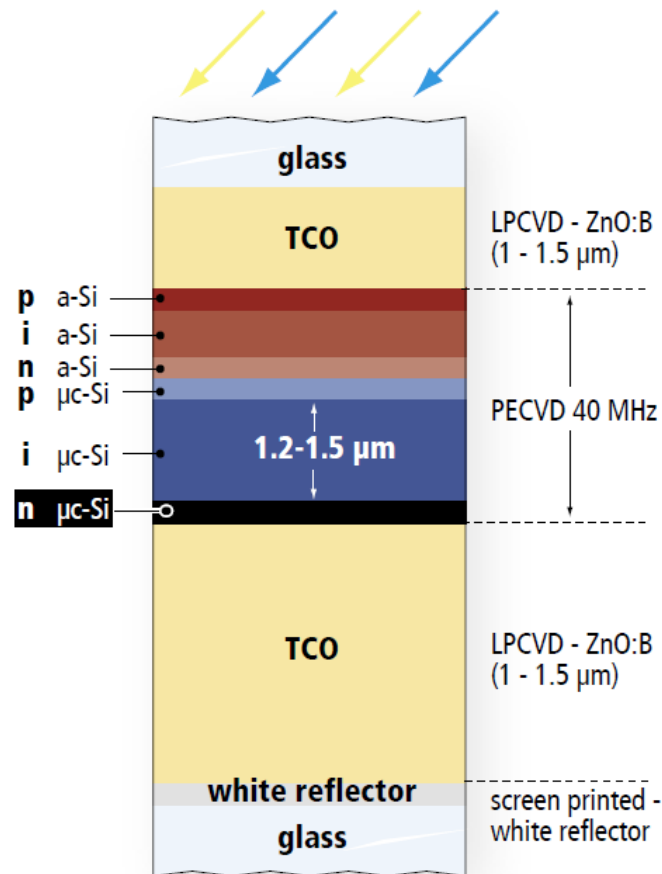

graphic: PHOTON International

# PV TECHNOLOGIES

## Amorphous silicon solar cells

In summary:

- **Low efficiency** (for the same yield requires more area: module framing & encapsulation become relevant costs)
- **Low cost** (may be interesting if land availability is not an issue)
- **Niche markets** such as building integrated PV, consumer electronics (i.e. gadgets), flexible solar cells,...

# PV TECHNOLOGIES

## Cadmium Telluride solar cells

- CdTe has a high absorption coefficient: thus **very thin** active layer
- Earliest paper on CdTe solar cell:  
Loferski J, *J. Appl. Phys.* 27, 777–784 (**1956**)
- Most ‘popular’ configuration: **CdTe/CdS** heterojunction (p-type CdTe and n-type CdS)

## Letters to the Editor

**P**UBLICATION of brief reports of important discoveries in physics may be secured by addressing them to this department. The closing date for this department is five weeks prior to the date of issue. No proof will be sent to the authors. The Board of Editors does not hold itself responsible for the opinions expressed by the correspondents. Communications should not exceed 600 words in length and should be submitted in duplicate.

### High-Voltage Photovoltaic Effect\*

L. PENSAC

RCA Laboratories, Princeton, New Jersey

(Received November 25, 1957)

**V**ACUUM evaporated films of cadmium telluride have been prepared that show unusually high photovoltages across their ends. The effect is independent of the electrode material and the voltage is proportional to the length of the film. A value of one hundred volts/cm has been obtained in sunlight. Since the photovoltage of a single junction is limited by the band gap of the material (1.45 ev), it is concluded that the films consist of large numbers of junctions (or other photovoltaic elements) whose individual voltages add to produce the observed values. Photovoltages greater than band gap have been reported for films of PbS,<sup>1,2</sup> but with a maximum of 3 volts and only after some post-evaporation processing. No such processing is required for the CdTe films.

The presence of the effect depends on the angle,  $\theta$ , of deposition of the vapor onto the substrate as shown in Fig. 1. Lines of constant  $\theta$  are found to be equipotentials for photovoltage. No photovoltage exists in material deposited with  $\theta=0$ . The photovoltage increases rapidly with  $\theta$  up to about 10 degrees and then very slowly up to 60 degrees, above which no measurements were taken. A second requirement for the effect is that the substrate be held at a temperature between 100 and 250°C during deposition. The pressure during evaporation,  $\sim 10^{-5}$  mm, is maintained by an oil diffusion pump.

The rate of film formation is about 1000 Å per minute. The films become photovoltaic when the thickness is sufficient to absorb some light, and the voltage increases to a maximum at approximately one micron. The effect occurs with Pyrex glass, fused quartz, and other substrate materials. The only requirement is that the substrate be more insulating than the films which, in the dark, have a resistance of the order of  $10^{13}$  ohms per square at room temperature.

The electrical properties of the films and their response to light and temperature are reported in a following letter. Optical transmission measurements show that the fundamental absorption edge is 8300 Å, the expected value for CdTe. X-ray studies by J. G. White of this Laboratory are consistent with the view that the films consist of crystallites whose size is comparable with the film thickness ( $\sim 1 \mu$ ). The crystallite (111) planes have a preferred orientation parallel to the substrate, regardless of the angle of deposition.

Although the effect has been found in every film made, the magnitude has not been reproducible within a factor of 10. An explicit model for the mechanism of the effect has not yet been established. An effect of comparable magnitude has been found in single-crystal zinc sulfide by another group in this laboratory. Further studies of the effect in both materials are under way.

\* This work was supported by the Evans Signal Corps Laboratories.

<sup>1</sup> Starkiewicz, Sosnowski, and Simpson, *Nature* **158**, 26 (1946).

<sup>2</sup> Berlaga, Rusmach, and Strakhov, *Zhur. Tekh. Fiz.* **25**, 1878 (1955).

### Properties of Photovoltaic Films of CdTe†

B. GOLDSTEIN

RCA Laboratories, Princeton, New Jersey

(Received November 25, 1957)

**T**HIS letter describes some of the basic properties of a representative photovoltaic film of CdTe.<sup>1</sup> The film was deposited onto a Pyrex substrate: it was one-half cm long, one cm wide, and about one micron thick. The open-circuit voltages were measured with a

# PV TECHNOLOGIES

## Cadmium Telluride solar cells

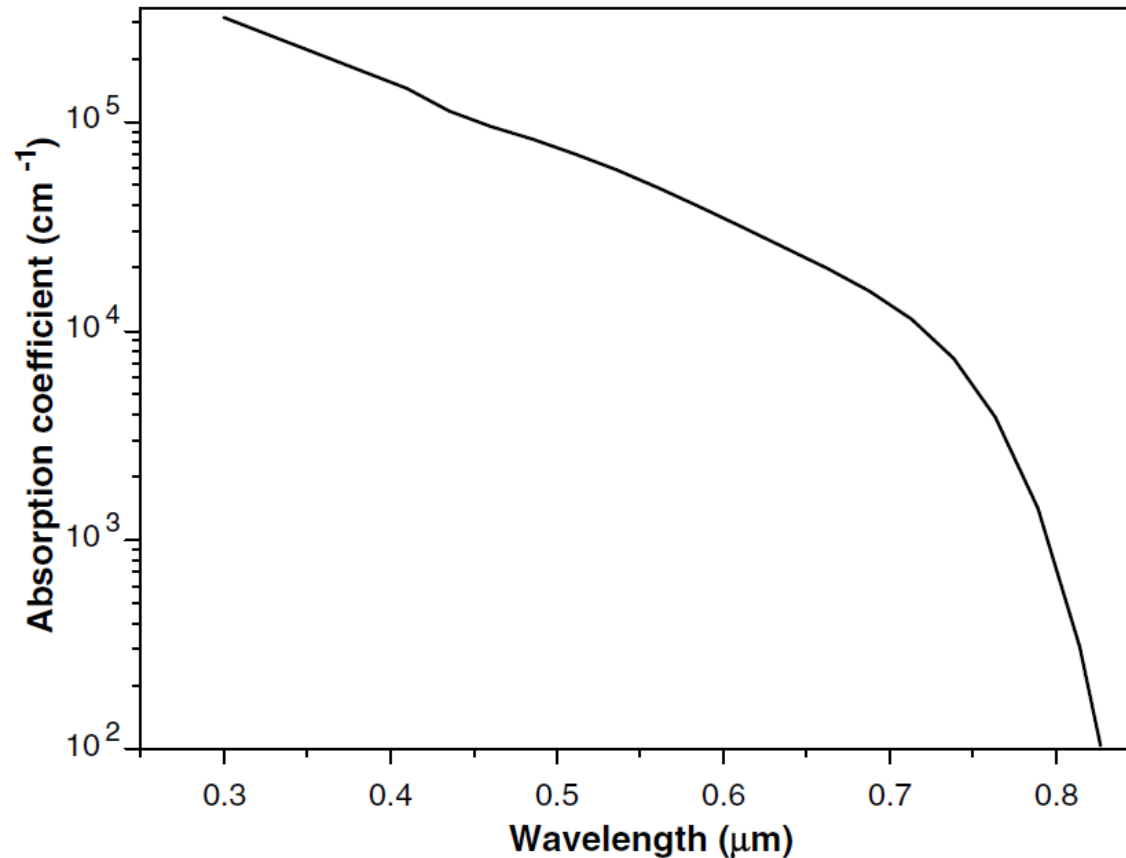
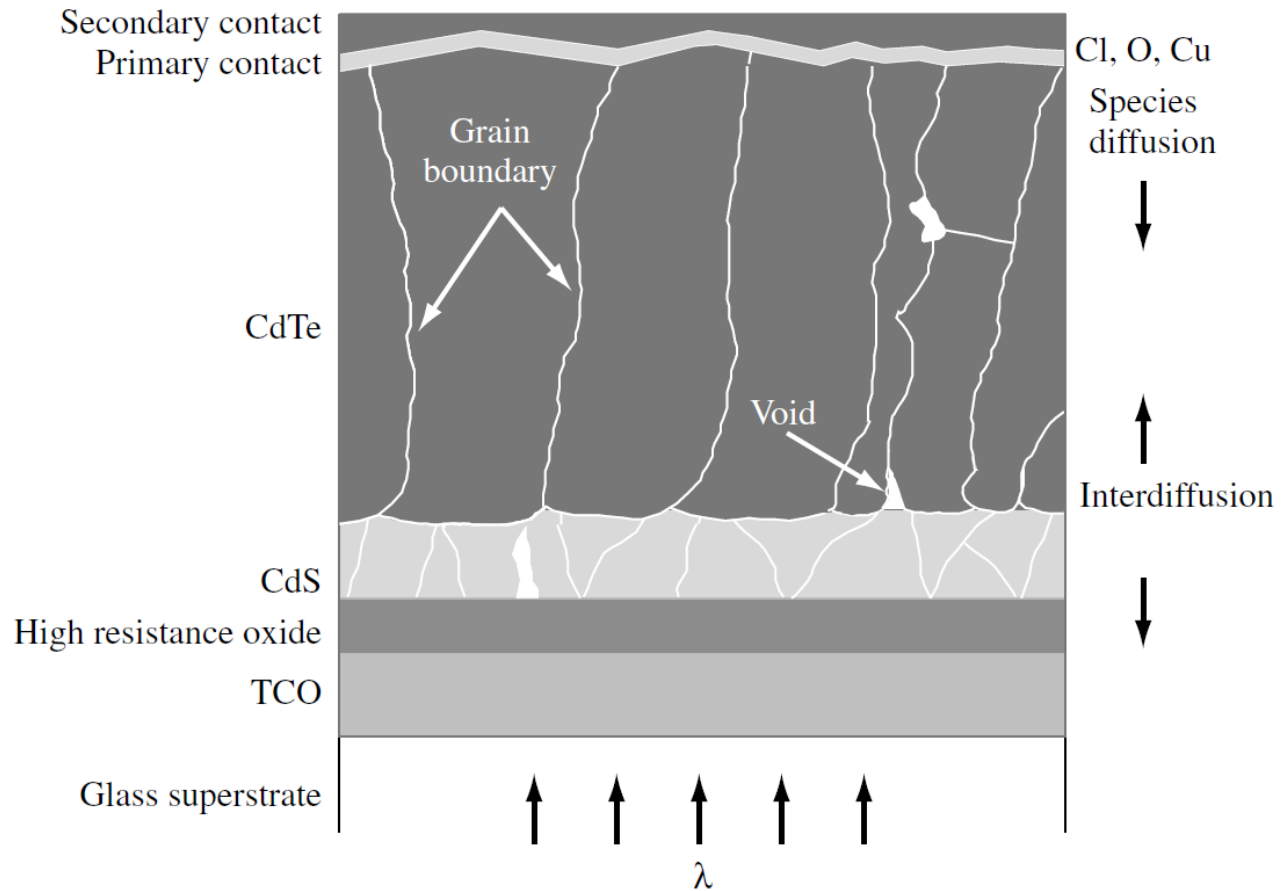

Fig. 5. CdTe absorption coefficient at room temperature.

# PV TECHNOLOGIES

## Cadmium Telluride solar cells



**Figure 14.7** Basic CdTe solar cell structure. The polycrystalline nature of the CdS and CdTe layers are indicated schematically and are not to scale

# PV TECHNOLOGIES

## Cadmium Telluride solar cells

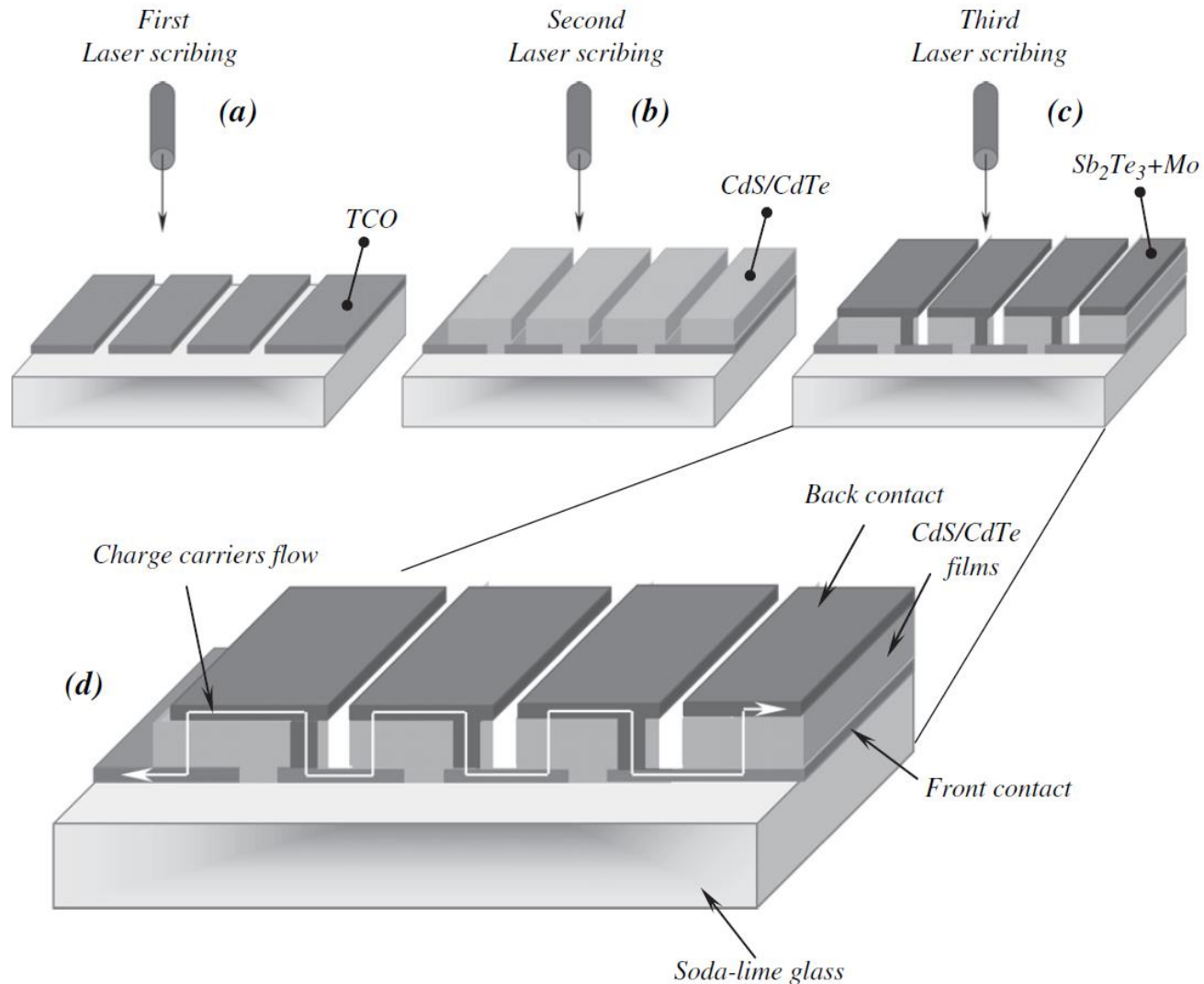

# PV TECHNOLOGIES

## Cadmium Telluride solar cells

- Top efficiencies:
  - Cell 16.7% (NREL);
  - Module 10.9% (BP Solarex);
  - Best seller: First Solar

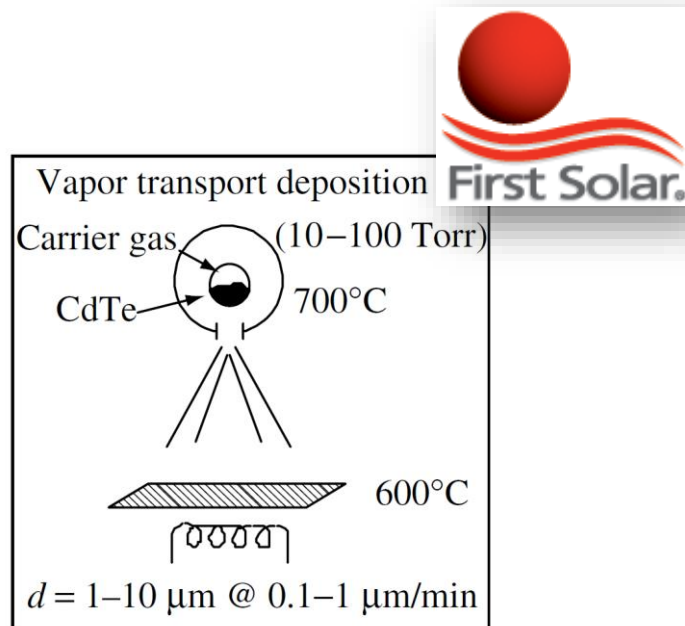

### Main issues:

- **Cheapest** technology in the market (<1 €/Wp)
- ‘Limited’ **efficiency**
- Reliability (**lifetime**)
- **Materials!!**
  - Toxic Cd
  - Rare Te
- **Window of opportunity taken!**

# PV TECHNOLOGIES

## Cu(InGa)Se<sub>2</sub> solar cells

- Synthesis and characterization were **first** reported by Hahn H et al., Z.Anorg.Allg. Chem. 271, 153–170 (1953)
- High absorption coefficient: **thin film**
- Like all thin films: potential for **cheap** manufacturing for fabrication of **monolithically interconnected** modules
- Potential for relatively **high efficiency**: 19.4% (cell) and 13.5% (module)

# PV TECHNOLOGIES

## Cu(InGa)Se<sub>2</sub> solar cells

- P-type: Cu(InGa)Se<sub>2</sub>
- N-type: CdS

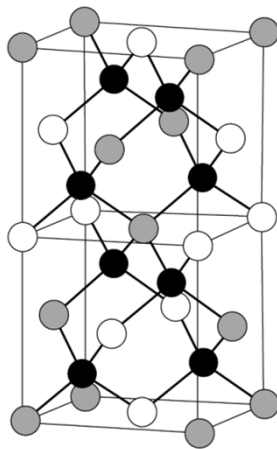

Cu ●  
In ○  
Se ●

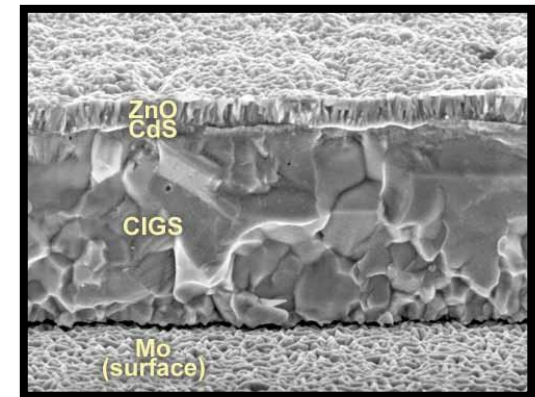
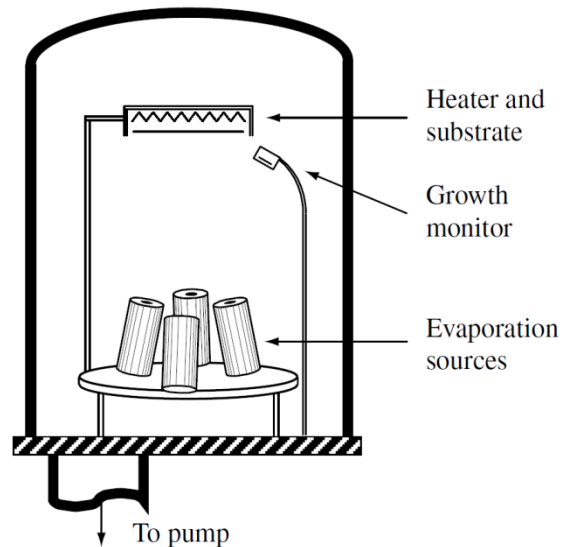

# PV TECHNOLOGIES

## Cu(InGa)Se<sub>2</sub> solar cells

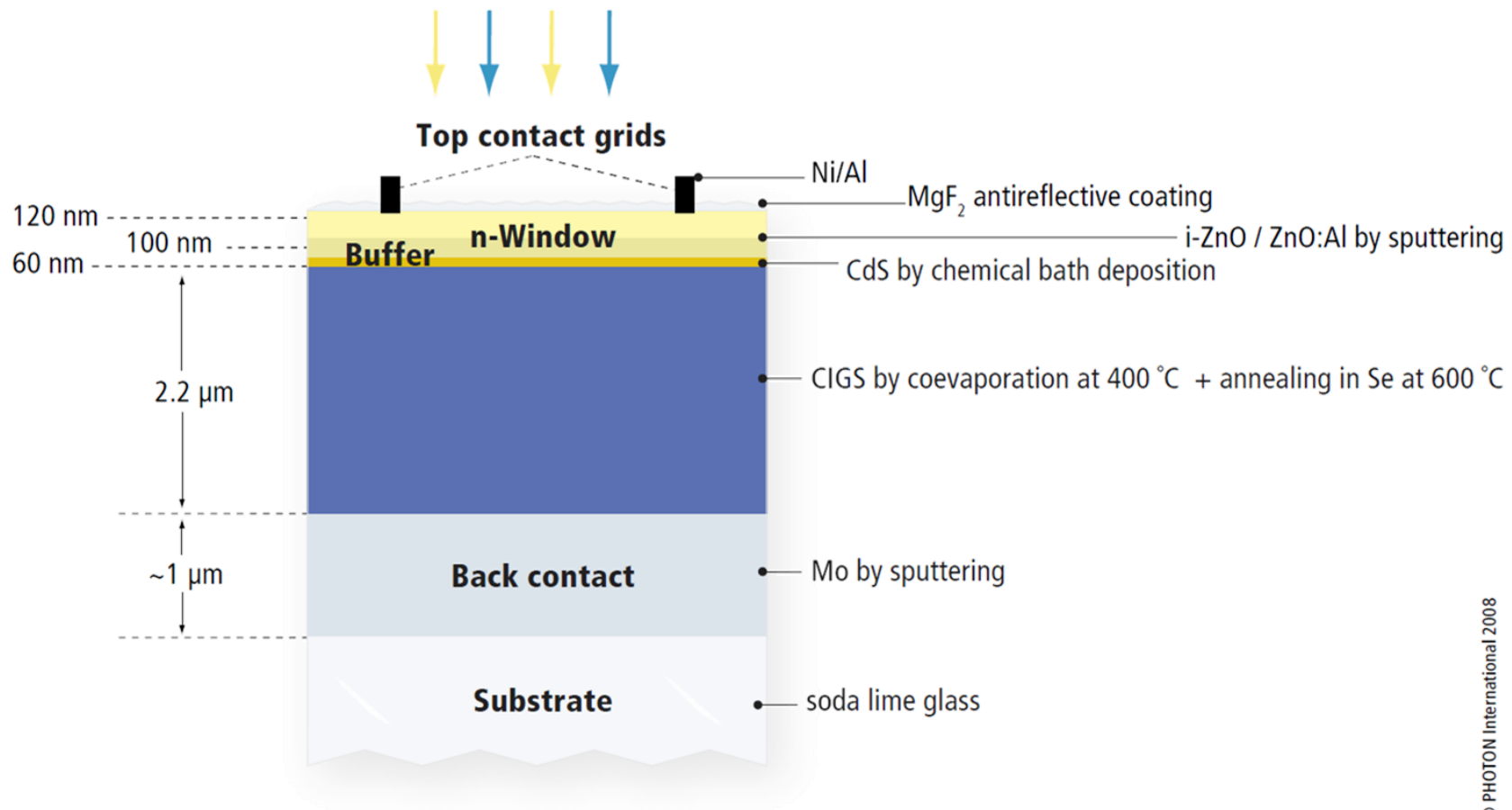

# PV TECHNOLOGIES

## Cu(InGa)Se<sub>2</sub> solar cells

- Other different CIGS concepts...

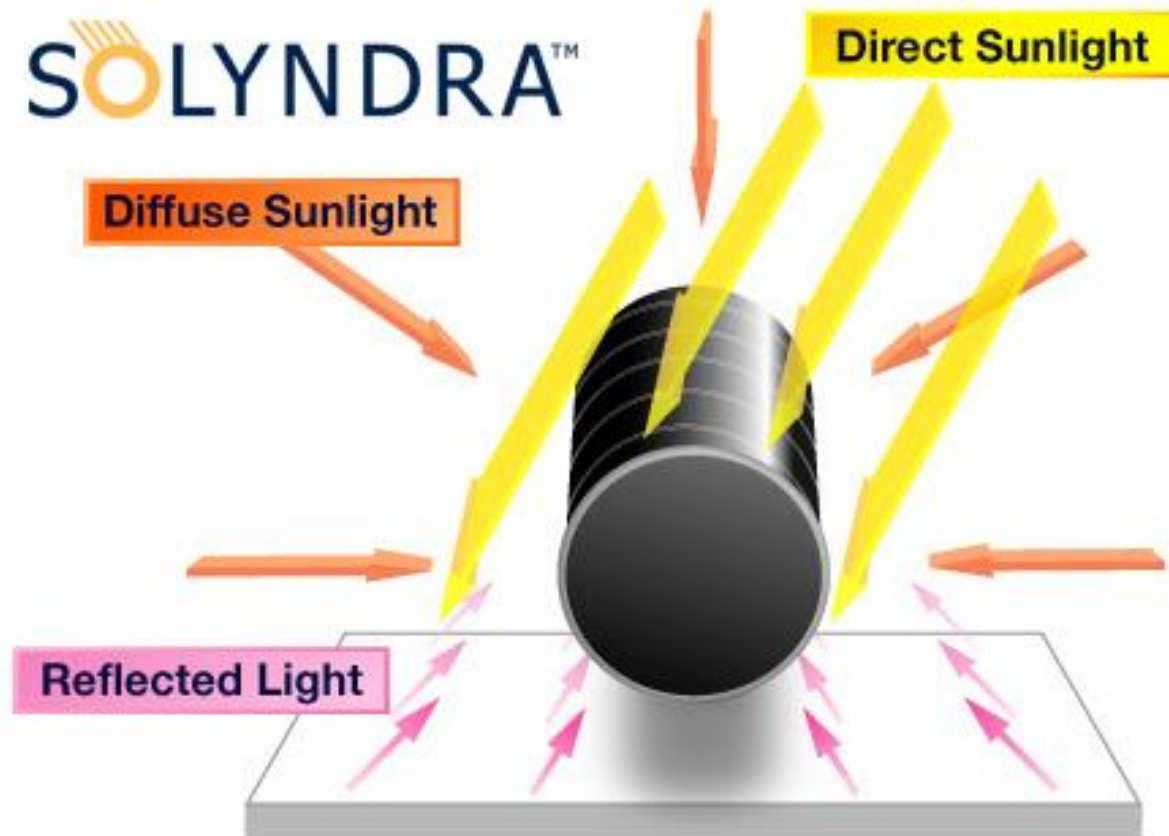

# PV TECHNOLOGIES

## Other technologies

- Many other different concepts...

CIGS  
nanoparticles

Polymer solar  
cells

Dye sensitized  
solar cells

Intermediate  
band cells

Thin silicon  
film

Silicon  
nanoparticle  
ink

DARPA  
(spectrum  
splitting)

# PV TECHNOLOGIES

## Other technologies

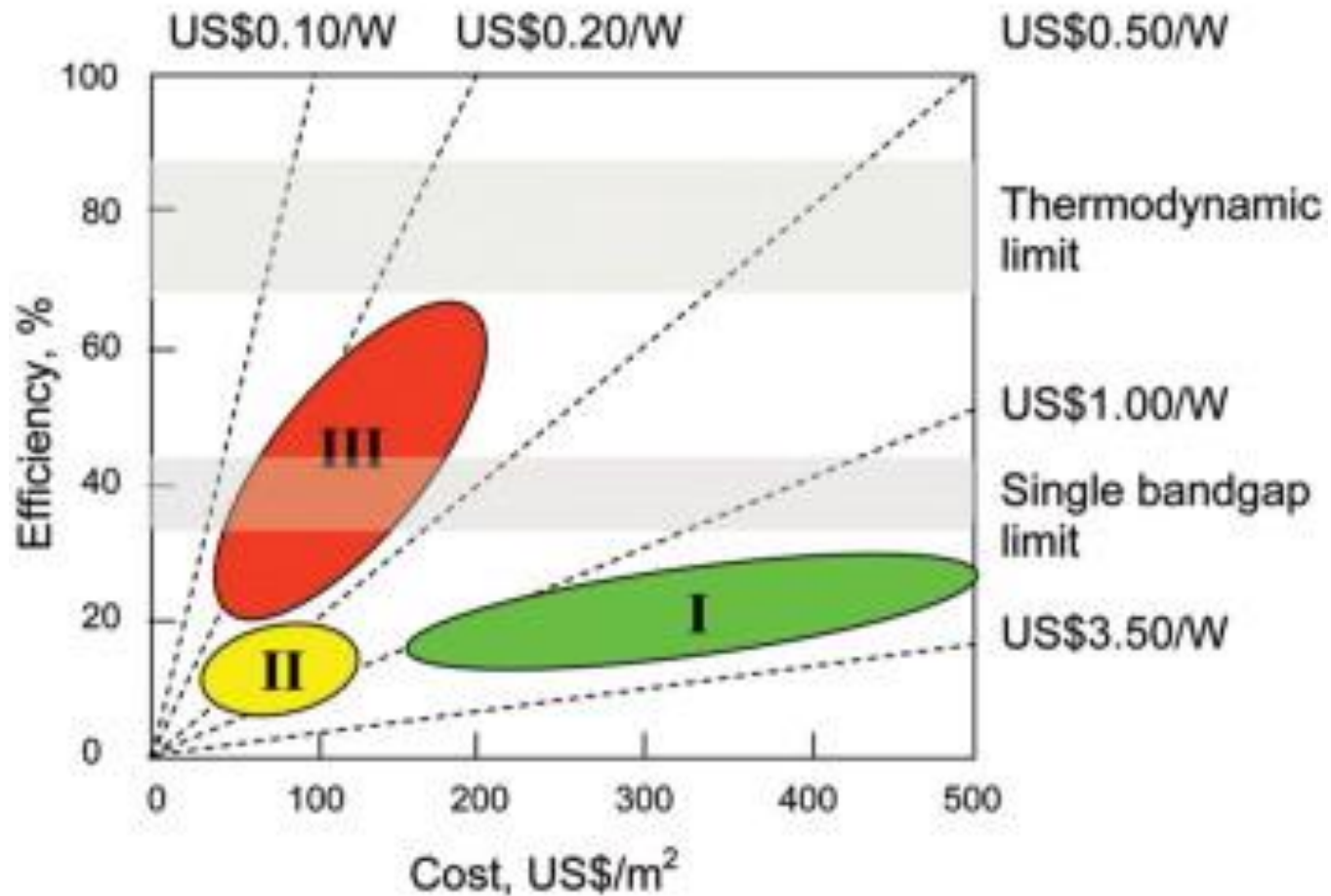

# PV TECHNOLOGIES

## Comparing different technologies



# PV TECHNOLOGIES

## Energy payback time

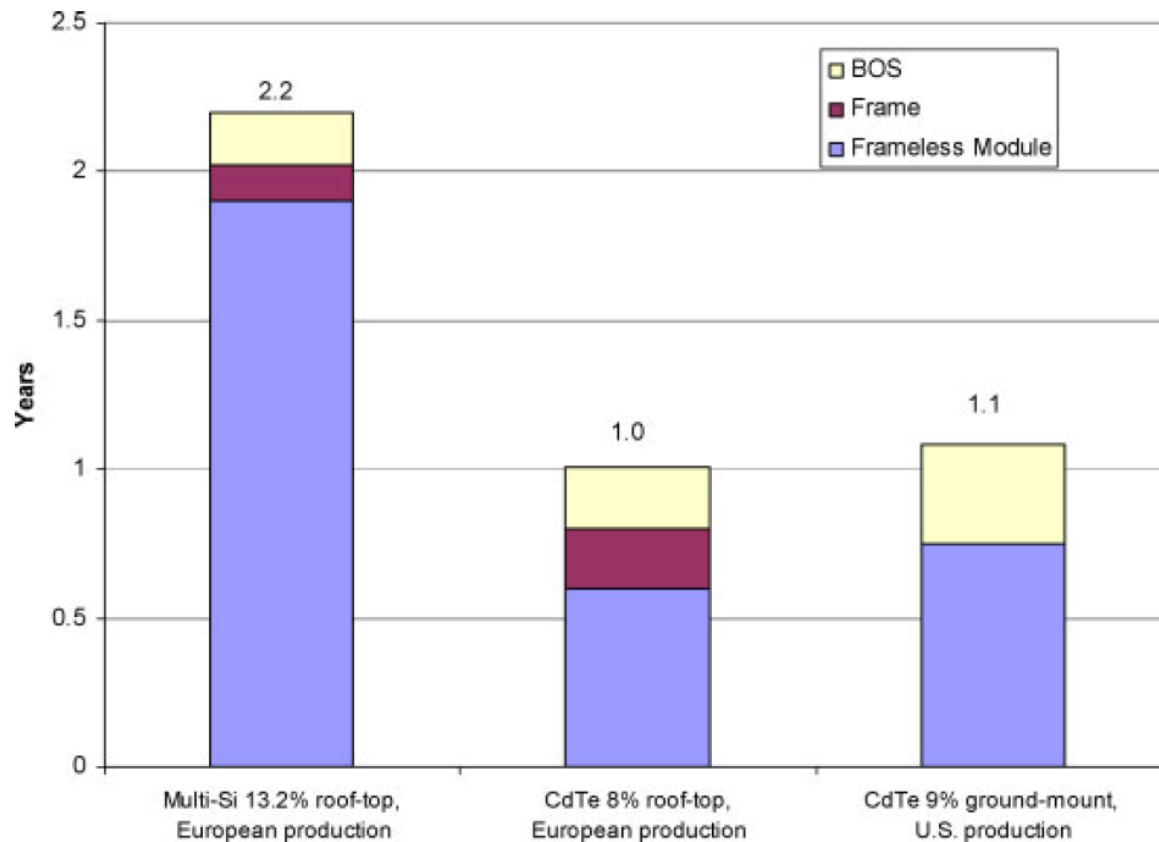

Figure 3. PV energy payback times of 2004 PV technologies for average southern Europe insolation ( $1700 \text{ kWh/m}^2/\text{yr}$ ), 75% performance ratio for roof-top installations, 80% performance ratio for utility ground-mount installations<sup>4-7</sup>

# PV TECHNOLOGIES

## Energy payback time

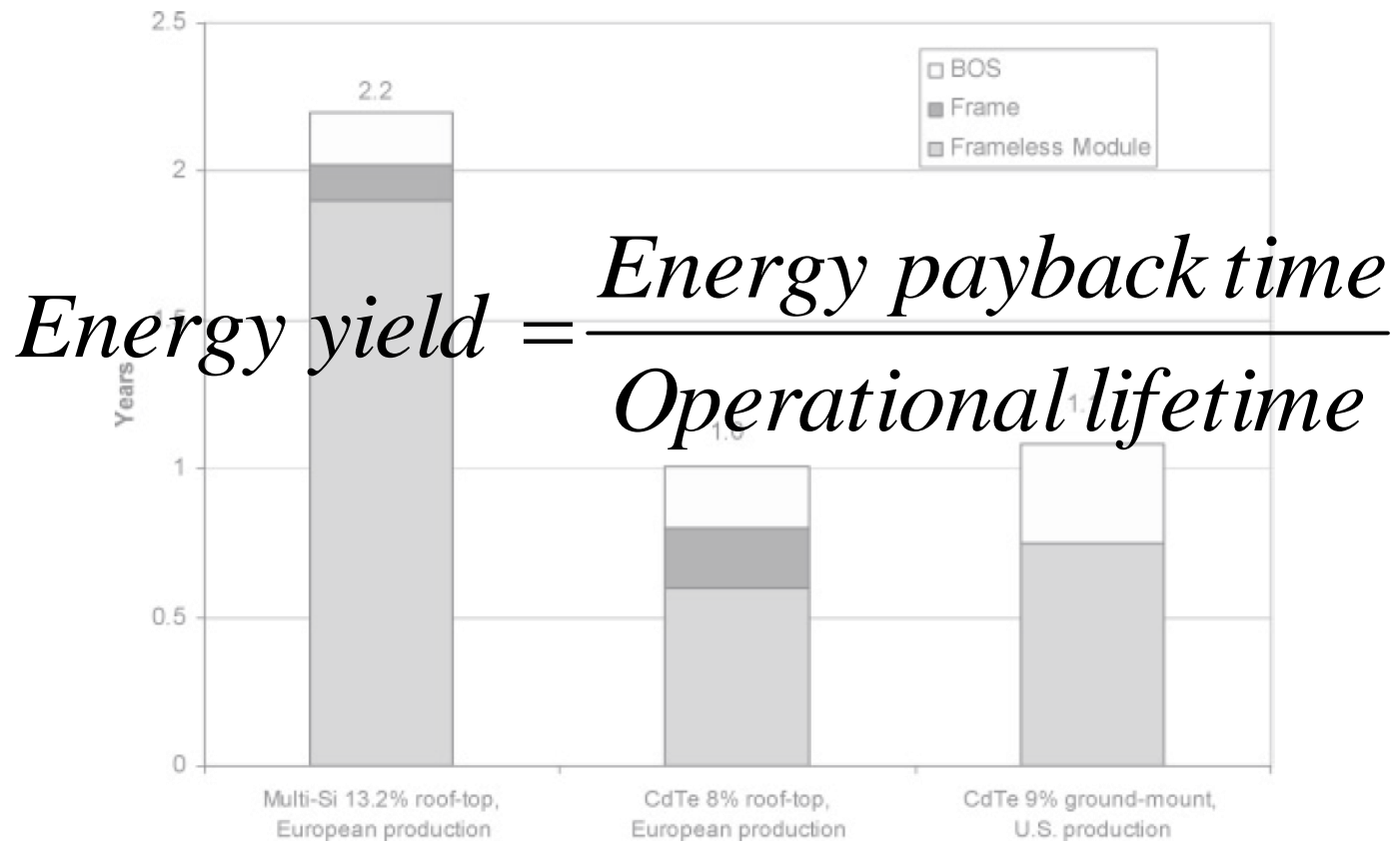
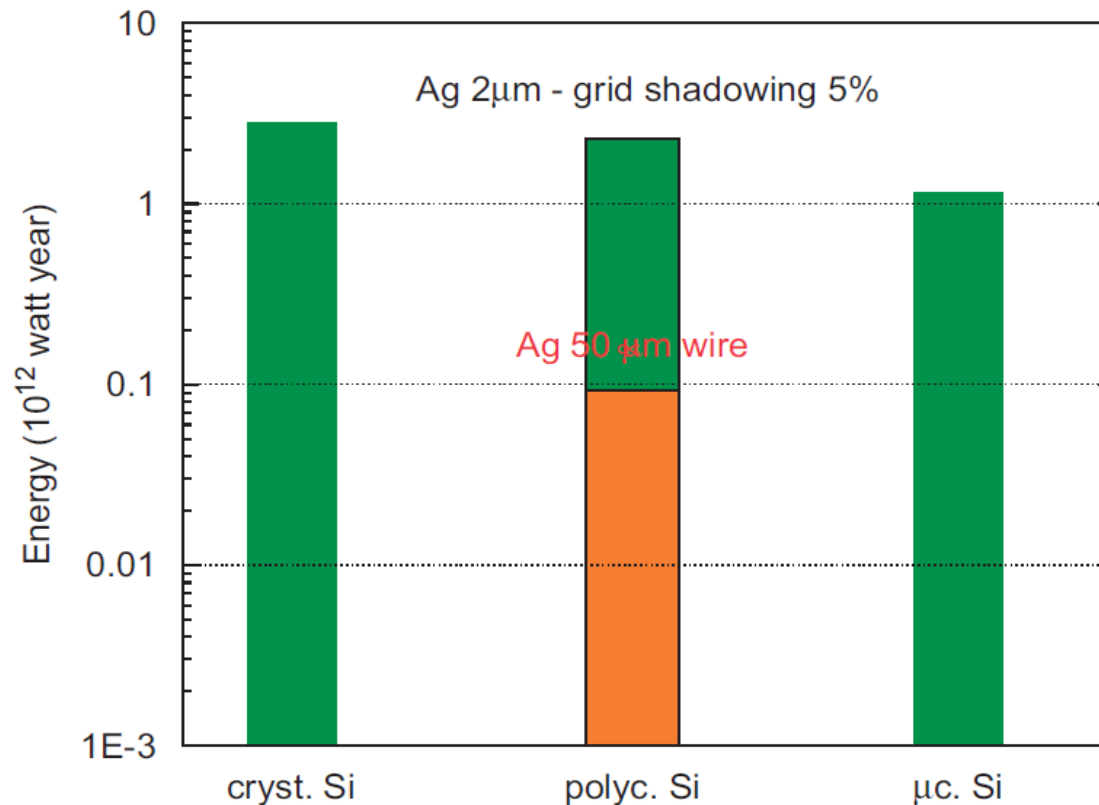

Figure 3. PV energy payback times of 2004 PV technologies for average southern Europe insolation (1700 kWh/m<sup>2</sup>/yr), 75% performance ratio for roof-top installations, 80% performance ratio for utility ground-mount installations<sup>4-7</sup>

# PV TECHNOLOGIES

## Materials availability



Potential energy limits imposed by global silver (Ag) reserves for bulk-like silicon photovoltaic technologies. The orange shaded area represents limits reached using 50 mm-thick Ag ribbons. The green shaded area represents limits estimated using a 2 mm thick Ag electrodes and 5% grid shadowing.

# PV TECHNOLOGIES

## Materials availability

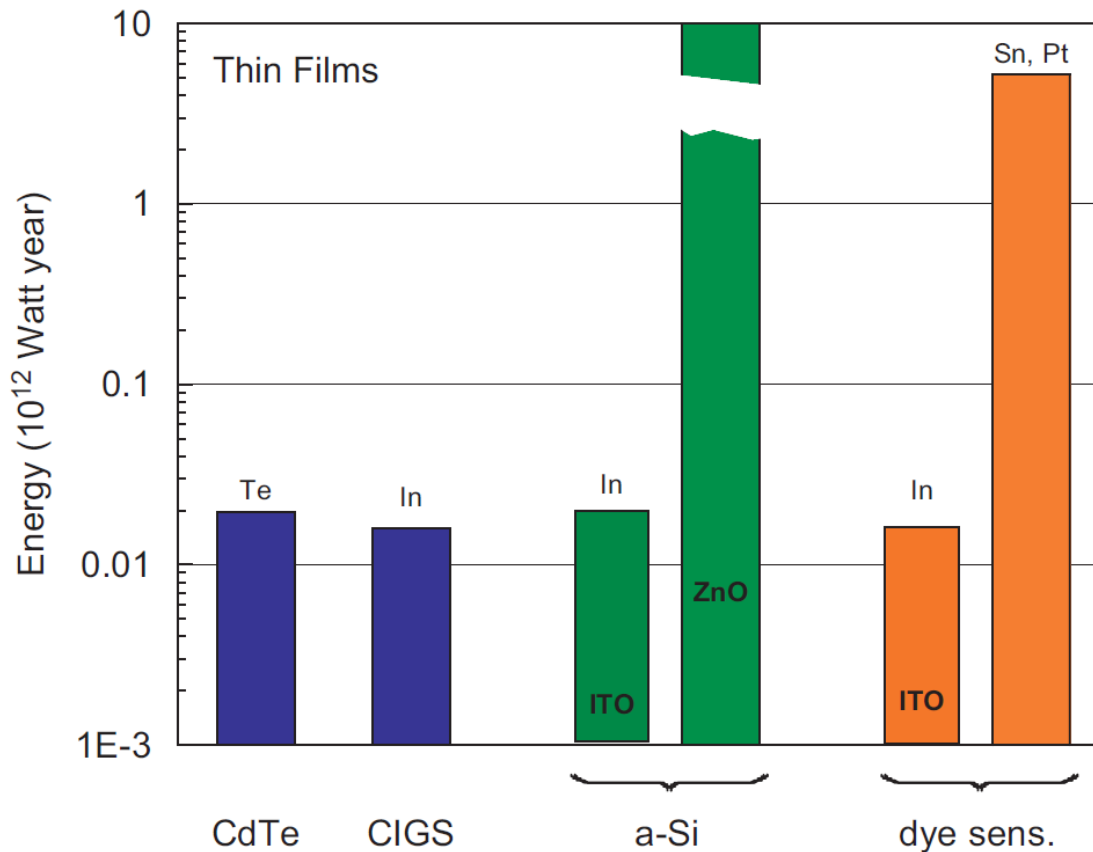

Fig. 4. Potential energy limits imposed for four different thin film photovoltaic technologies.

# PV TECHNOLOGIES

## Materials availability

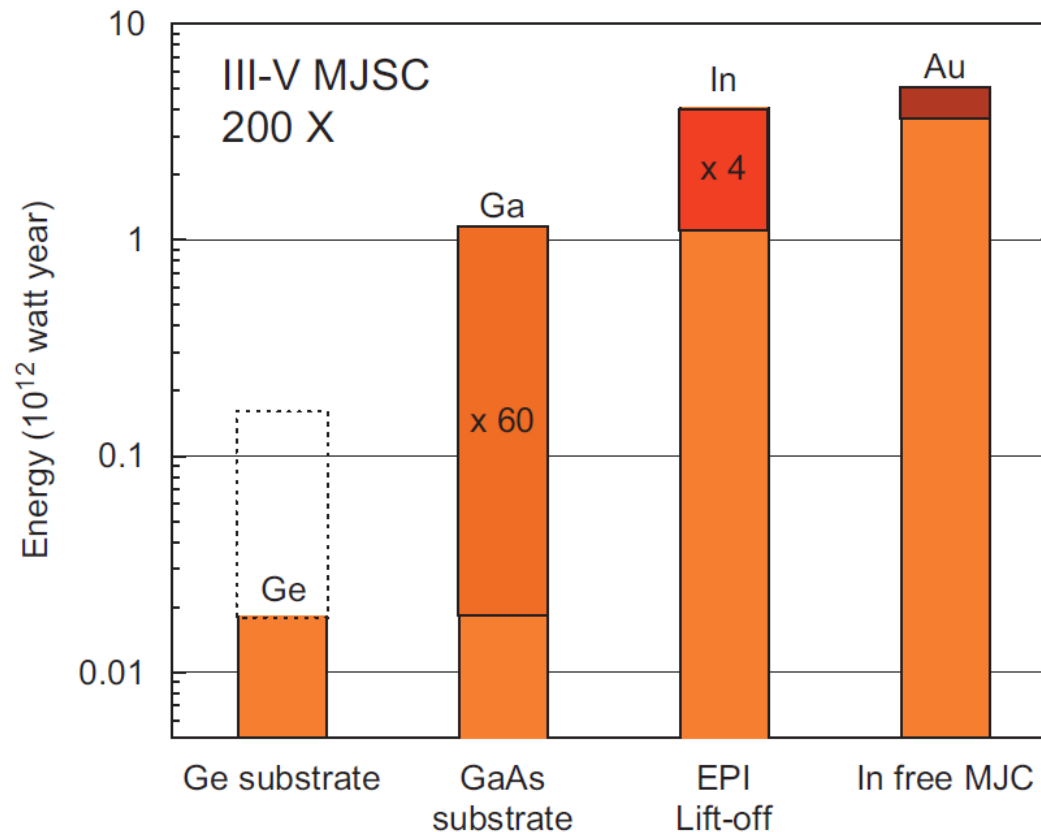

Fig. 5. Potential energy limits imposed to III–V multi-junction cells (200 sun concentrations). The third and fourth columns show the extrapolated potential of this technology if lift-off/cell exfoliation techniques are adopted.

# PV TECHNOLOGIES

## Comparing different technologies

Considering all these factors...

- Silicon technologies are to dominate the market in the foreseeable future
- Opportunities for other technologies with industrial scale, in particular CdTe (e.g. First Solar)
- Niche markets are breeding ground for other 'new' technologies (thin films in BIPV or flexible applications, concentration for large solar power plants, etc)

# PV TECHNOLOGIES

## Other technologies

### Further reading

- Luque and Hegedus, *Handbook of Photovoltaic Science and Engineering*. Edited by, John Wiley & Sons 2003 (Chp 6, 7, 12, 13, 14)
- Goetzberger, *Photovoltaic Solar Energy Conversion*, Springer 2005 (Chp 3)
- Sha et al, *Thin-film silicon solar cell technology*, Prog. Photovolt: Res.Appl. 2004; 12:113–142 (DOI: 10.1002/pip.533)
- Bosio et al, *Polycrystalline CdTe thin films for photovoltaic applications*, Progress in Crystal Growth and Characterization of Materials, 52 (2006) 247-279
- Morales-Acevedo, *Thin film CdS/CdTe solar cells: Research perspectives*, Solar Energy 80 (2006) 675–681
- Fthenakis, E. Alsema, *Photovoltaics energy payback times, greenhouse gas emissions and external costs*, Prog. Photovolt: Res.Appl. 2006; 14:275–280 [Check Fthenakis's page: [www.bnl.gov/pv](http://www.bnl.gov/pv)]
- Feltrin, Freundlich, *Material considerations for TW level deployment of PV*, Renewable Energy 33 (2008) 180–185